

YAMAHA YZF1000R Thunderace



Total performance with absolute control.

Right now the Yamaha YZF1000R Thunderace is by far the most technologically advanced large-capacity supersport machine that money can buy.

Plus a whole lot more. And here's why.

For a start this incredibly fast motorcycle is the only machine in its class to be powered by a low centre of gravity slant-block engine equipped with 5-valve heads and our race-developed torque-boosting EXUP (Exhaust Ultimate Powervalve) exhaust system. Making this the quickest production Yamaha street bike—ever!

And the latest Thunderace is also the only one-litre supersport bike to run with a 750-class short wheelbase aluminium Deltabox chassis. Which ensures outstanding cornering precision on challenging back roads as well as express train straight-line stability on the highway.

But above all the YZF1000R is a sophisticated rider's machine whose integrated design, unrivalled technology and advanced aerodynamics come together to deliver total performance. And absolute control.



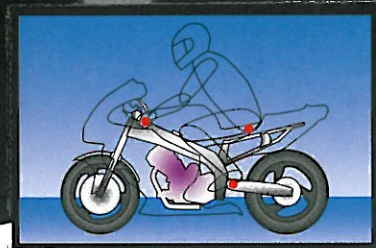

D

tre of gra-
t design.
ecification.
outrageous



Displacing 1000 cc, the latest generation liquid-cooled YZF engine features our race-developed slant-block layout which keeps the centre of gravity low for razor-sharp handling.

Breathing through a massive airbox, four BDSR 38 mm downdraft carburetors force-feed the motor with their explosive mix for instant throttle response—while Yamaha's innovative 5-valve head design ensures outstanding combustion efficiency to give impressive flexibility at all speeds.

Equipped with a lightweight crankshaft and racing-style forged pistons, this power-plant is built to

deliver the most awesome acceleration you could imagine. And with its unique EXUP system—which constantly alters the pipe's internal aperture to match rpm—the YZF delivers rubber-squealing torque right through the range.

Packed out with state-of-the-art technology—including both TPS (Throttle Position Sensor) and GPS (Gear Position Sensor) for ideal ignition timing, as well as a large-capacity curved radiator—this high-performance 1000 cc engine is the one that they're all trying to catch!

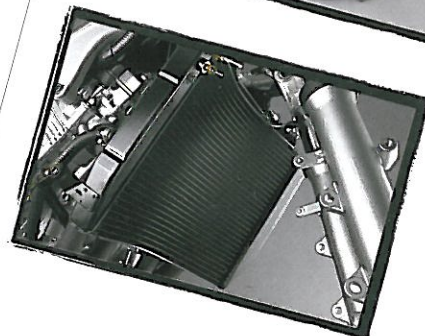
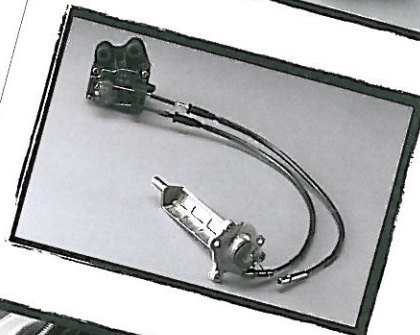
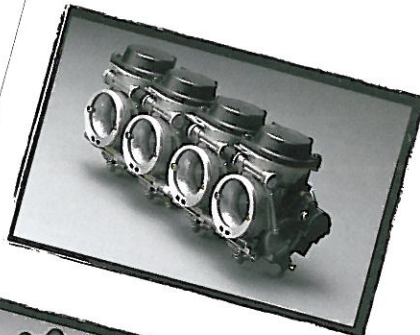
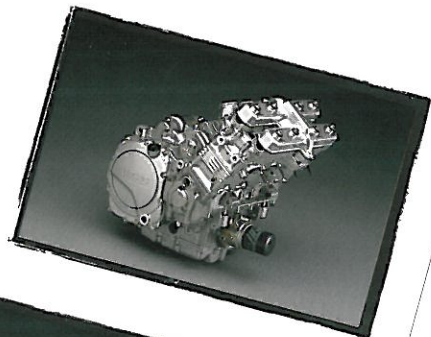



Extreme technology. Supreme capability.

In today's highly competitive supersport scene there is one powerplant that commands total respect.

Running with a special 5-valve head design, advanced downdraft carburetors, torque-boosting EXUP and a low centre of gravity slant-block layout, the new generation YZF1000R engine represents the cutting edge in high-performance powerplant design.

No other large-capacity supersport motorcycle comes close to challenging the Thunderace's superbike racer-based specification.

And out in the real world of sweeping bends and snaking mountain passes the YZF's mind-bending acceleration and outrageous full-on performance push the supersport experience right to the edge.



1

ix chassis
iding

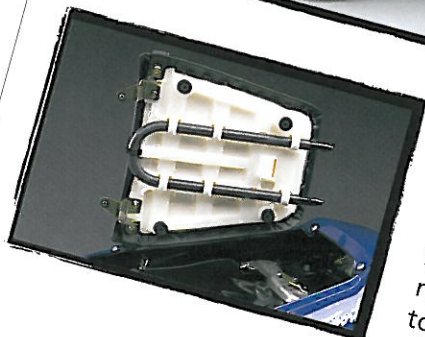
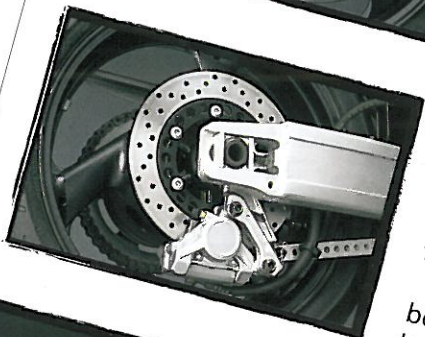
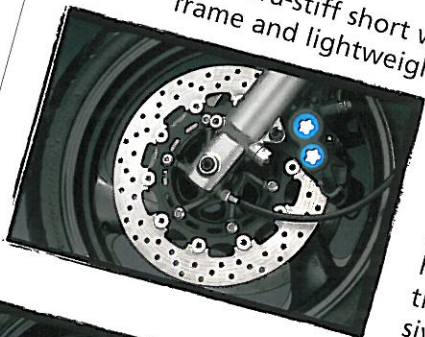
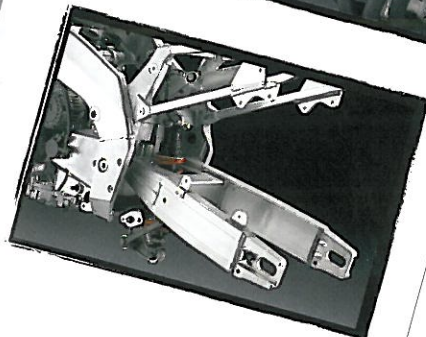
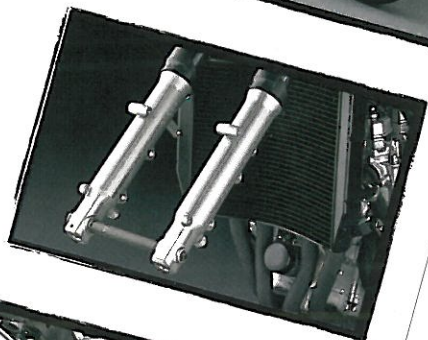

The very same advanced technology that gives our World Superbike racers the advantage on the track

Thunderace one of the leading supersport bikes of our time. Ultra-stiff short wheelbase aluminium Deltabox frame and lightweight aluminium swinging arm elevate the YZF's handling to a whole new level.

Fully adjustable suspension is constructed to the highest specifications, with massive flex-resistant 48 mm front forks complemented by a heavy-duty rear shock. Which adds up to excellent road-holding characteristics allied with class-leading rider comfort.

Widely regarded as being one of the best in the business, the Thunderace's state-of-the-art braking system features lightweight one-piece callipers slowing dual 298 mm discs that generate remarkable stopping power.

To complete this high-quality chassis package the YZF runs with lightweight 3-spoke wheels for responsive handling. And for added security the '97 model comes fully equipped with an under-seat U-lock storage space, specially hardened ignition switch and an all-new wiring harness designed to facilitate the fitting of electronic al-

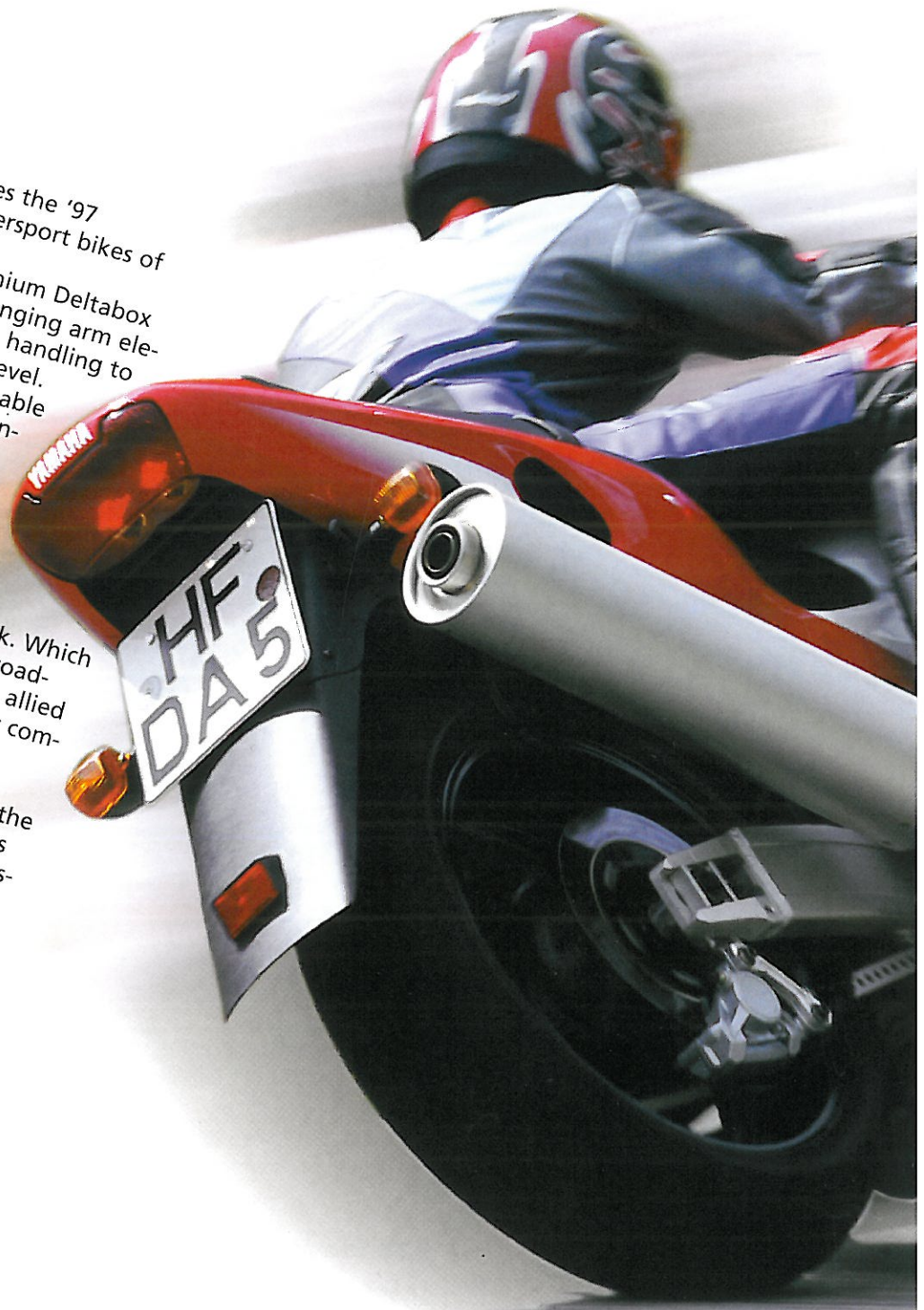



Programmed for the ultimate experience.

Based around the short wheelbase dimensions used on our World Superbike racers, the YZF1000R's aluminium Deltabox chassis combines extremely low weight with enormous rigidity—the two essentials for precision handling.

Running with fully adjustable suspension, super-efficient triple disc braking system and a remarkably comfortable riding position for a supersport bike, the latest Thunderace has got to be one of the most balanced total packages in the class.

Which allows you to unleash the potential of the fastest in-line four-cylinder Yamaha production engine ever built!





BWC1

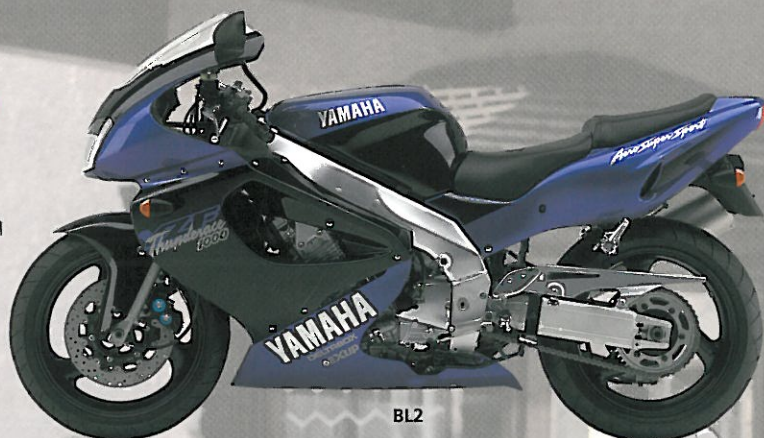

BL2

YZF1000R Thunderace

Technical Specifications

ENGINE

Type Liquid-cooled, 4-stroke DOHC,
forward inclined parallel 4-cylinder
Displacement 1,002 cc
Bore and stroke 75.5 x 56 mm
Compression ratio 11.5 : 1
Maximum power
(DIN) 145 HP (106.7 kW)
@ 10,000 rpm
(ISO) 137.8 HP (103 kW)
@ 10,000 rpm
Maximum torque 11 kg-m (108 Nm)
@ 8,500 rpm
Starting system Electric
Carburation BDSR38 x 4
Lubrication Wet sump
Fuel tank capacity 20 litres
Fuel reserve amount 4,5 litres

TRANSMISSION

Primary reduction ratio 68/41 (1.659)
Secondary reduction ratio 46/17 (2.706)
Transmission type 5-speed constant mesh
Gear ratio 1st 36/14 (2.571)
Gear ratio 2nd 32/18 (1.778)
Gear ratio 3rd 29/21 (1.381)
Gear ratio 4th 27/23 (1.174)
Gear ratio 5th 28/27 (1.037)
Final transmission Chain
Ignition T.C.I. (digital)

CHASSIS

Overall length 2,085 mm
Overall width 740 mm
Overall height 1,175 mm
Seat height 815 mm
Wheelbase 1,430 mm
Min. ground clearance 140 mm
Dry weight 198 kg
Caster angle 24°
Trail 97 mm

SUSPENSION

Front suspension Telescopic fork
Front shock Rebound/compression adjustable
Front fork travel 120 mm
Rear suspension Monocross
Rear shock Rebound/compression adjustable
Rear shock travel 65 mm
Front wheel travel 120 mm
Rear wheel travel 120 mm
Front tyre size 120/70 ZR17
Rear tyre size 180/55 ZR17

FRONT WHEEL

Rim size MT3.50 x 17
Rim material Aluminium

REAR WHEEL

Rim size MT5.50 x 17
Rim material Aluminium

BRAKES

Front brake type Dual disc brakes (298 mm)
Rear brake type Single disc brake (245 mm)

Always wear a helmet, eye protection and protective clothing.

Yamaha encourage you to ride safely and respect fellow riders and the environment.

Specifications and appearance of Yamaha products shown here may vary according to requirements and conditions, and are subject to change without notice.

For further details, please consult your Yamaha dealer.

DEALER

Yamaha Motor (U.K.) Ltd.

Sopwith Drive
The Brooklands Industrial Park
Brooklands, Weybridge, Surrey KT13 0UZ
Tel: 0932 35 80 00

Yamaha Motor (U.K.) Ltd.
use and recommend



YAMAHA MOTOR EUROPE N.V.
LIT-3MC-0107026-97E