



OWNER'S MANUAL

Thunderace

YZF1000R

4SV-28199-E3

Welcome to the Yamaha world of motorcycling!

As the owner of a YZF1000R, you are benefiting from Yamaha's vast experience in and newest technology for the design and the manufacture of high-quality products, which have earned Yamaha a reputation for dependability.

Please take the time to read this manual thoroughly, so as to enjoy all your YZF1000R's advantages. The owner's manual does not only instruct you in how to operate, inspect and maintain your motorcycle, but also in how to safeguard yourself and others from trouble and injury.

In addition, the many tips given in this manual will help to keep your motorcycle in the best possible condition. If you have any further questions, do not hesitate to contact your Yamaha dealer.

The Yamaha team wishes you many safe and pleasant rides. So, remember to put safety first!

IMPORTANT MANUAL INFORMATION

EAU00005

Particularly important information is distinguished in this manual by the following notations:



The Safety Alert Symbol means ATTENTION! BECOME ALERT! YOUR SAFETY IS INVOLVED!



Failure to follow WARNING instructions could result in severe injury or death to the motorcycle operator, a bystander or a person inspecting or repairing the motorcycle.

CAUTION:

A CAUTION indicates special precautions that must be taken to avoid damage to the motorcycle.

NOTE:

A NOTE provides key information to make procedures easier or clearer.

NOTE:

- This manual should be considered a permanent part of this motorcycle and should remain with it even if the motorcycle is subsequently sold.
 - Yamaha continually seeks advancements in product design and quality. Therefore, while this manual contains the most current product information available at the time of printing, there may be minor discrepancies between your motorcycle and this manual. If there is any question concerning this manual, please consult your Yamaha dealer.
-

IMPORTANT MANUAL INFORMATION

EW000002

 **WARNING**

PLEASE READ THIS MANUAL CAREFULLY AND COMPLETELY BEFORE OPERATING THIS MOTORCYCLE.

IMPORTANT MANUAL INFORMATION

EAU00008

**YZF1000R
OWNER'S MANUAL
© 1999 by Yamaha Motor Co., Ltd.
1st Edition, August 1999
All rights reserved. Any reprinting or
unauthorized use without the written
permission of Yamaha Motor Co., Ltd.
is expressly prohibited.
Printed in Japan.**

1 GIVE SAFETY THE RIGHT OF WAY	1
2 DESCRIPTION	2
3 INSTRUMENT AND CONTROL FUNCTIONS	3
4 PRE-OPERATION CHECKS	4
5 OPERATION AND IMPORTANT RIDING POINTS	5
6 PERIODIC MAINTENANCE AND MINOR REPAIR	6
7 MOTORCYCLE CARE AND STORAGE	7
8 SPECIFICATIONS	8
9 CONSUMER INFORMATION	9
INDEX	



GIVE SAFETY THE RIGHT OF WAY

GIVE SAFETY THE RIGHT OF WAY 1-1



Motorcycles are fascinating vehicles, which can give you an unsurpassed feeling of power and freedom. However, they also impose certain limits, which you must accept; even the best motorcycle does not ignore the laws of physics.

Regular care and maintenance are essential for preserving your motorcycle's value and operating condition. Moreover, what is true for the motorcycle is also true for the rider: good performance depends on being in good shape. Riding under the influence of medication, drugs and alcohol is, of course, out of the question. Motorcycle riders - more than car drivers - must always be at their mental and physical best. Under the influence of even small amounts of alcohol, there is a tendency to take dangerous risks.

Protective clothing is as essential for the motorcycle rider as seat belts are for car drivers and passengers. Always wear a complete motorcycle suit (whether made of leather or tear-resistant synthetic materials with protectors), sturdy boots, motorcycle gloves and a properly fitting helmet. Optimum protective wear, however, should not encourage carelessness. Though full-coverage helmets and suits, in particular, create an illusion of total safety and protection, motorcyclists will always be vulnerable. Riders who lack critical self-control run the risk of going too fast and are apt to take chances. This is even more dangerous in wet weather. The good motorcyclist rides safely, predictably and defensively - avoiding all dangers, including those caused by others.

Enjoy your ride!

Left view	2-1
Right view.....	2-2
Controls/Instruments.....	2-3

Left view

2

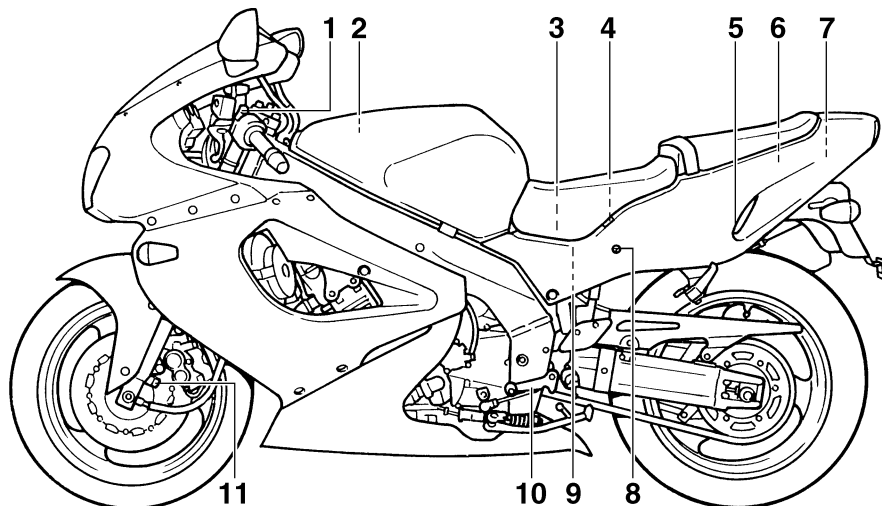

- | | | | |
|------------------------|-------------|--|-------------|
| 1. Starter (choke) “ ” | (page 3-13) | 8. Rear shock absorber compression damping force adjusting screw | (page 3-17) |
| 2. Air filter | (page 6-12) | 9. Main fuse | (page 6-28) |
| 3. Fuse box | (page 6-28) | 10. Shift pedal | (page 3-10) |
| 4. Helmet holder | (page 3-14) | 11. Front fork compression damping force adjusting screw | (page 3-16) |
| 5. Rider seat lock | (page 3-13) | | |
| 6. Storage compartment | (page 3-15) | | |
| 7. Tool kit | (page 6-1) | | |

Right view

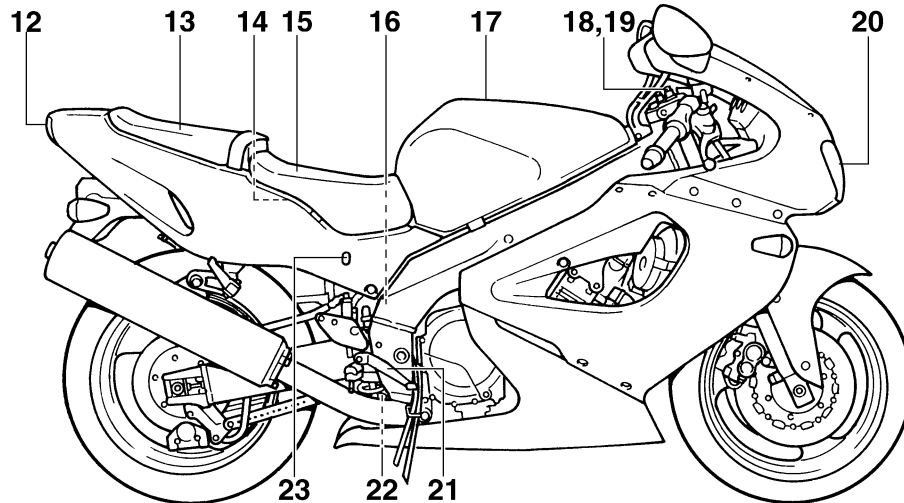

- | | | | |
|--|-------------|---|-------------|
| 12. Tail/brake light | (page 6-30) | 19. Front fork rebound damping force
adjusting screw | (page 3-16) |
| 13. Passenger seat | (page 3-14) | 20. Headlight | (page 6-29) |
| 14. Coolant reservoir tank | (page 6-11) | 21. Rear brake pedal | (page 3-11) |
| 15. Rider seat | (page 3-13) | 22. Rear shock absorber rebound damping
force adjusting knob | (page 3-18) |
| 16. Rear shock absorber spring preload
adjusting ring | (page 3-17) | 23. Rear brake fluid level check window | |
| 17. Fuel tank | (page 3-11) | | |
| 18. Front fork spring preload adjusting bolt | (page 3-15) | | |

DESCRIPTION

Controls/Instruments

2

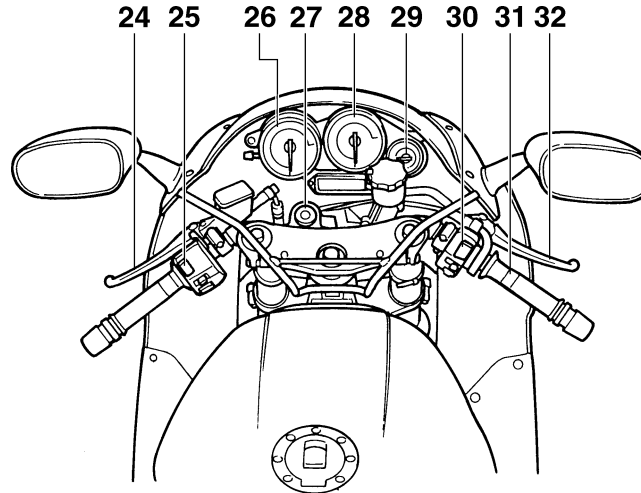

- | | |
|-------------------------------|-------------|
| 24. Clutch lever | (page 3-9) |
| 25. Left handlebar switches | (page 3-8) |
| 26. Speedometer | (page 3-6) |
| 27. Main switch/steering lock | (page 3-1) |
| 28. Tachometer | (page 3-6) |
| 29. Coolant temperature gauge | (page 3-7) |
| 30. Right handlebar switches | (page 3-9) |
| 31. Throttle grip | (page 6-15) |
| 32. Front brake lever | (page 3-10) |

INSTRUMENT AND CONTROL FUNCTIONS

Main switch/steering lock.....	3-1	Fuel tank cap	3-11
Indicator lights	3-2	Fuel	3-12
Oil level indicator circuit check.....	3-3	Fuel tank breather hose (for Germany only)	3-13
Fuel indicator circuit check	3-5	Starter (choke) “ \ ”	3-13
Speedometer	3-6	Seats	3-13
Tachometer	3-6	Helmet holder.....	3-14
Diagnosis device.....	3-7	Storage compartment	3-15
Coolant temperature gauge	3-7	Front fork adjustment	3-15
Handlebar switches	3-8	Rear shock absorber adjustment	3-17
Clutch lever	3-9	Luggage strap holders	3-19
Shift pedal.....	3-10	EXUP (EXhaust Ultimate Powervalve).....	3-19
Front brake lever	3-10	Sidestand	3-19
Rear brake pedal	3-11	Sidestand/clutch switch operation check.....	3-20

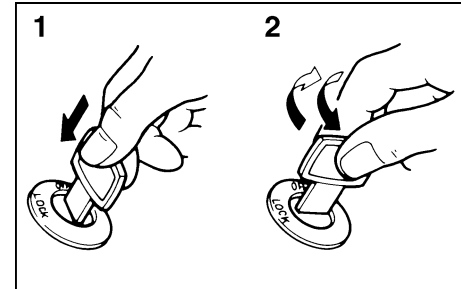
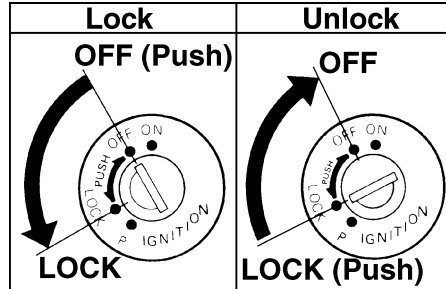
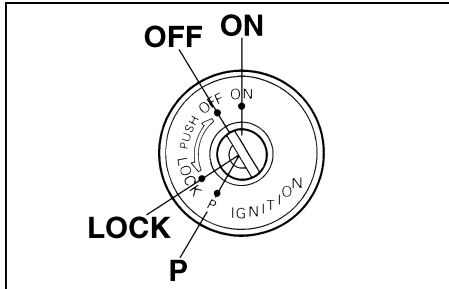

1. Push
2. Turn

EAU00029*

Main switch/steering lock

The main switch controls the ignition and lighting systems. Its operation is described below.

EAU00036

ON

Electrical circuits are switched on. The engine can be started. The key cannot be removed in this position.

EAU00038

OFF

All electrical circuits are switched off. The key can be removed in this position.

EAU00040

LOCK

The steering is locked in this position and all electrical circuits are switched off. The key can be removed in this position.

To lock the steering, turn the handlebars all the way to the left. While pushing the key into the main switch, turn it from "OFF" to "LOCK" and remove it.

To release the lock, turn the key to "OFF" while pushing.

EW000016

! WARNING

Never turn the key to "OFF" or "LOCK" when the motorcycle is moving. The electrical circuits will be switched off which may result in loss of control or an accident. Be sure the motorcycle is stopped before turning the key to "OFF" or "LOCK".

INSTRUMENT AND CONTROL FUNCTIONS

P (Parking)

EAU00048

The steering is locked in this position, and the taillight and auxiliary light come on but all other circuits are off. The key can be removed in this position.

To use the parking position, first lock the steering, then turn the key to "P". Do not use this position for an extended length of time as the battery may discharge.

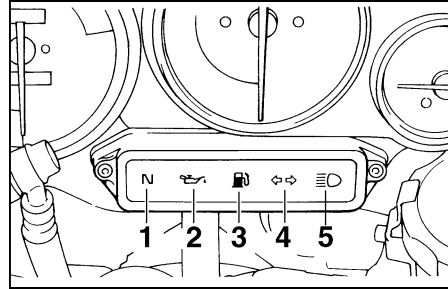

1. Neutral indicator light "N"
2. Oil level indicator light "🛢️"
3. Fuel indicator light "🛢️"
4. Turn indicator light "↔️"
5. High beam indicator light "≡🔦"

Indicator lights

EAU00056

Turn indicator light "↔️"

EAU00057

This indicator flashes when the turn switch is moved to the left or right.

Neutral indicator light "N"

EAU00061

This indicator comes on when the transmission is in neutral.

High beam indicator light "≡🔦"

EAU00063

This indicator comes on when the headlight high beam is used.

Oil level indicator light "🛢️"

EAU01313

This indicator comes on when the oil level is low. This light circuit can be checked by the procedure on page 3-3.

3

EC000000

CAUTION:

Do not run the motorcycle until you know it has sufficient engine oil.

NOTE:

Even if the oil is filled to the specified level, the indicator light may flicker when riding on a slope or during sudden acceleration or deceleration, but this is normal.

INSTRUMENT AND CONTROL FUNCTIONS

EAU00071

Oil level indicator circuit check

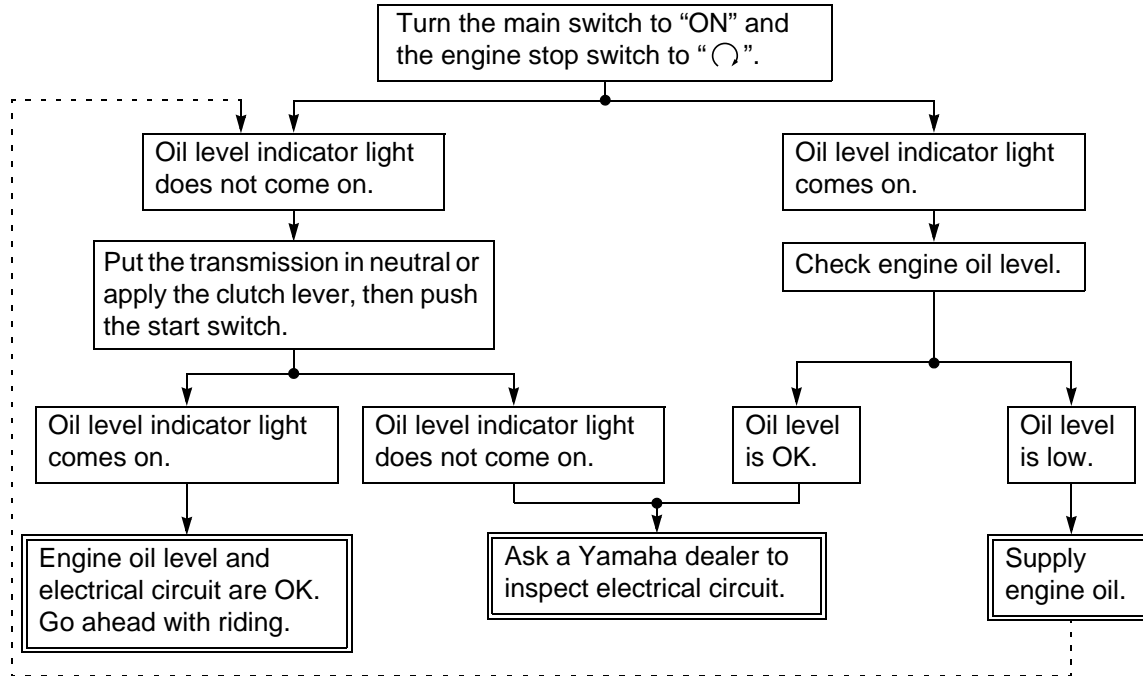

3

EAU01154

Fuel indicator light “”

When the fuel level drops below approximately 4.5 L, this light will come on. When this light comes on, fill the tank at the first opportunity. This light circuit can be checked by the procedure on page 3-5.

INSTRUMENT AND CONTROL FUNCTIONS

EAU00085

Fuel indicator circuit check

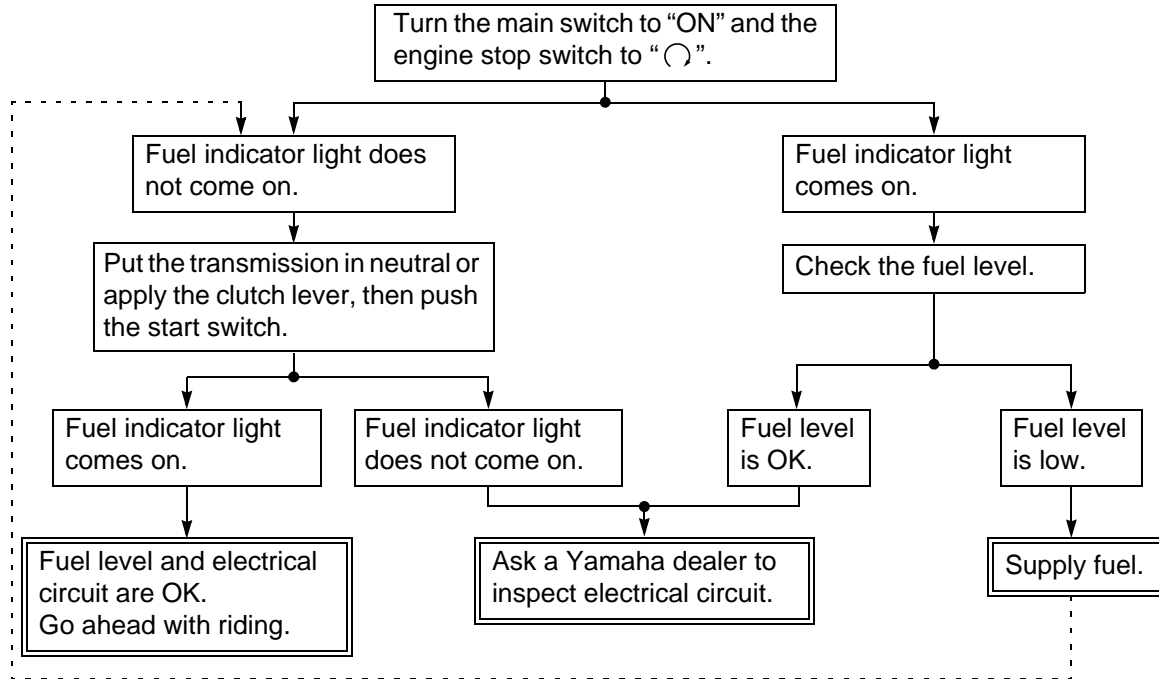

3

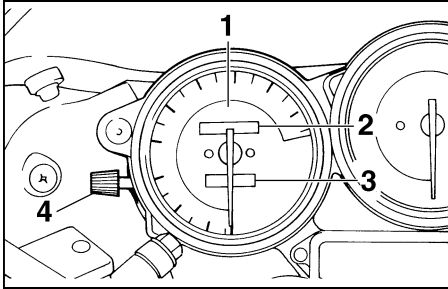

1. Speedometer
2. Odometer
3. Trip odometer
4. Reset knob

EAU00095

Speedometer

The speedometer shows riding speed. This speedometer is equipped with an odometer and trip odometer. The trip odometer can be reset to “0” with the reset knob. Use the trip odometer to estimate how far you can ride on a tank of fuel. This information will enable you to plan fuel stops in the future.

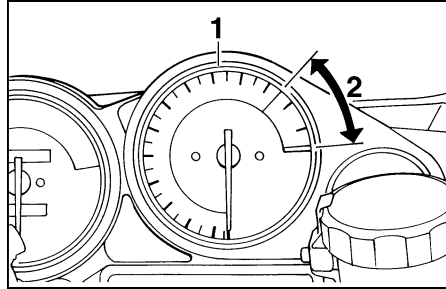

1. Tachometer
2. Red zone

EAU00101

Tachometer

This model is equipped with an electric tachometer so the rider can monitor the engine speed and keep it within the ideal power range.

EC000003

CAUTION:

Do not operate in the red zone.
Red zone: 11,500 r/min and above

INSTRUMENT AND CONTROL FUNCTIONS

Diagnosis device

EAU00106

This model is equipped with a self diagnosis for the following circuits.

- Throttle Position Sensor (T.P.S.) circuit
- Exhaust Ultimate Power valve (EXUP) circuit
- Fuel level indicator circuit

If some trouble should occur in any of these circuits, the tachometer will repeatedly display as follows:

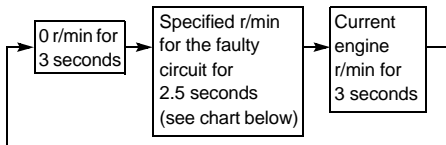

Use this chart to identify what circuit is faulty according to the specified r/min displayed.

Specified r/min	Faulty circuit
3,000 r/min	Throttle Position Sensor (T.P.S.)
7,000 r/min	Exhaust Ultimate Power valve (EXUP)
8,000 r/min	Fuel level indicator

If the tachometer displays as described above, take note of the specified r/min and then take your motorcycle to a Yamaha dealer for repair.

EC000004

CAUTION:

To prevent engine damage, be sure to consult a Yamaha dealer as soon as possible if the tachometer displays a repeated change in r/min.

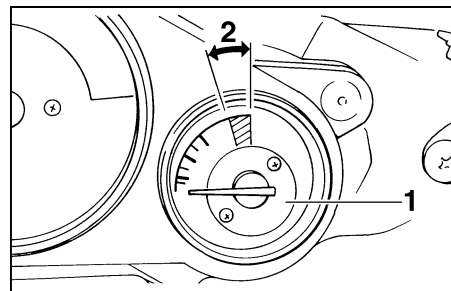

1. Coolant temperature gauge
2. Red zone

EAU01652

Coolant temperature gauge

This gauge indicates the coolant temperature when the main switch is on. The engine operating temperature will vary with changes in weather and engine load. If the needle points to the red zone or higher, stop your motorcycle and let the engine cool. (See page 6-11 for details.)

EC000002

CAUTION:

When the engine is overheated, do not continue riding.

EAU00127

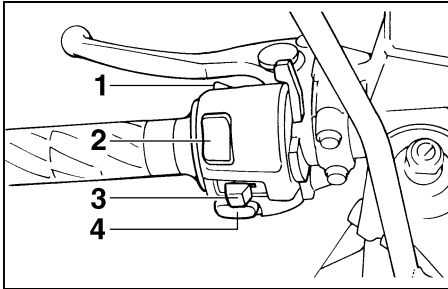

1. Pass switch "PASS"
2. Dimmer switch
3. Turn signal switch
4. Horn switch "📢"

EAU00118

Handlebar switches

EAU00120

Pass switch "PASS"

Press the switch to operate the passing light.

EAU00121

Dimmer switch

Turn the switch to "☰" for the high beam and to "☷" for the low beam.

Turn signal switch

To signal a right-hand turn, push the switch to "➡". To signal a left-hand turn, push the switch to "⬅". Once the switch is released it will return to the center position. To cancel the signal, push the switch in after it has returned to the center position.

EAU00130

Horn switch "📢"

Press the switch to sound the horn.

INSTRUMENT AND CONTROL FUNCTIONS

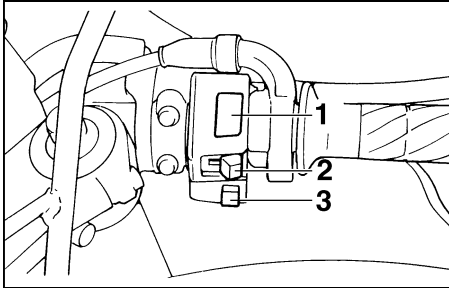

3



1. Engine stop switch
2. Lights switch
3. Start switch “”



EAU00134

Lights switch

Turning the light switch to “”, turns on the auxiliary light, meter lights and taillight. Turning the light switch to “” turns the headlight on also.

EAU00138

Engine stop switch

The engine stop switch is a safety device for use in an emergency such as when the motorcycle overturns or if trouble occurs in the throttle system. Turn the switch to “” to start the engine. In case of emergency, turn the switch to “” to stop the engine.

EAU00141

Start switch “”

The starter motor cranks the engine when pushing the start switch.

EC000005

CAUTION:

See starting instructions prior to starting the engine.

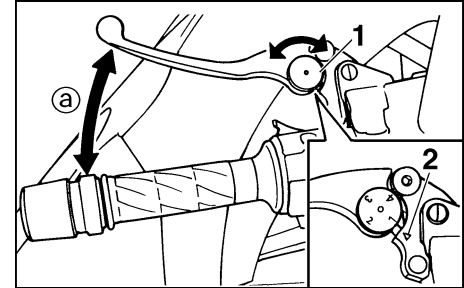

1. Lever position adjusting dial
2. Arrow mark
- a. Lever distance

EAU00153

Clutch lever

The clutch lever is located on the left handlebar. It is equipped with a clutch lever adjusting dial and a clutch switch, which is integrated into the ignition circuit cut-off system. (Refer to the engine starting procedures for a description of this system.)

To disengage the clutch, pull the clutch lever toward the handlebar. To engage the clutch, release the lever. The lever should be pulled rapidly and released slowly for smooth clutch operation.

INSTRUMENT AND CONTROL FUNCTIONS

To adjust the distance between the clutch lever and the handlebar grip, turn the clutch adjusting dial while pushing the lever forward. Make sure the setting on the clutch lever adjusting dial is aligned with the arrow mark.

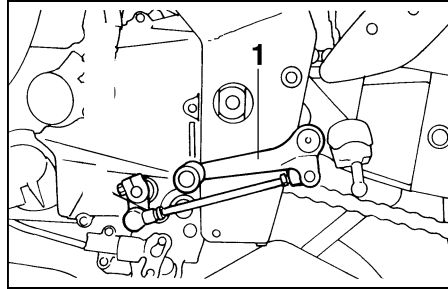

1. Shift pedal

EAU00157

Shift pedal

This motorcycle is equipped with a constant-mesh 5-speed transmission. The shift pedal is located on the left side of the engine and is used in combination with the clutch when shifting.

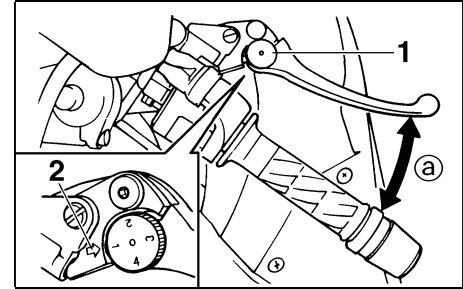

1. Lever position adjusting dial
2. Arrow mark
a. Lever distance

EAU00161

Front brake lever

The front brake lever is located on the right handlebar and is equipped with a brake lever adjusting dial. To activate the front brake, pull the lever toward the handlebar.

To adjust the front brake lever position, turn the brake lever adjusting dial while pulling the lever forward. Make sure the setting on the brake lever adjusting dial is aligned with the arrow mark.

INSTRUMENT AND CONTROL FUNCTIONS

3

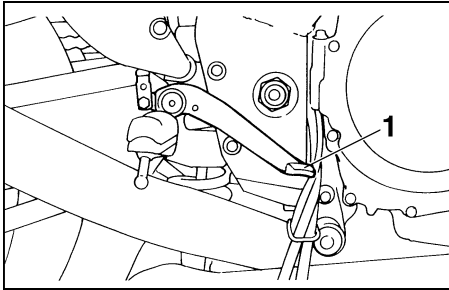

1. Rear brake pedal

EAU00162

Rear brake pedal

The rear brake pedal is on the right side of the motorcycle. Press down on the brake pedal to apply the rear brake.

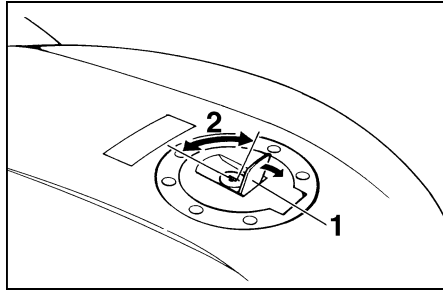

1. Lock cover
2. Open

EAU02935

Fuel tank cap

To open

Open the lock cover. Insert the key and turn it 1/4 turn clockwise. The lock will be released and the cap can be opened.

To close

Push the tank cap into position with the key inserted. To remove the key, turn it counterclockwise to the original position. Then, close the lock cover.

NOTE:

This tank cap cannot be closed unless the key is in the lock. The key cannot be removed if the cap is not locked properly.

EW000023

! WARNING

Be sure the cap is properly installed and locked in place before riding the motorcycle.

INSTRUMENT AND CONTROL FUNCTIONS

EAU00186

EAU00191

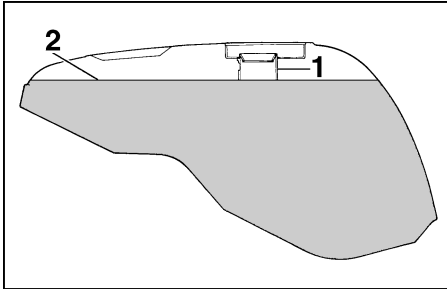

1. Filler tube
2. Fuel level

EAU00183

Fuel

Make sure there is sufficient fuel in the tank. Fill the fuel tank to the bottom of the filler tube as shown in the illustration.

EW000130

WARNING

Do not overfill the fuel tank. Avoid spilling fuel on the hot engine. Do not fill the fuel tank above the bottom of the filler tube or it may overflow when the fuel heats up later and expands.

CAUTION:

- **Always wipe off spilled fuel immediately with a dry and clean soft cloth. Fuel may deteriorate painted surfaces or plastic parts.**
- **(For Germany only)**
The fuel tank cap equipped on German models is specially designed. Always use the correct cap whenever replacement is necessary.

Recommended fuel:

Regular unleaded gasoline with a research octane number of 91 or higher.

Fuel tank capacity:

Total:

20 L

Reserve:

4.5 L

NOTE:

If knocking or pinging occurs, use a different brand of gasoline or higher octane grade.

INSTRUMENT AND CONTROL FUNCTIONS

3

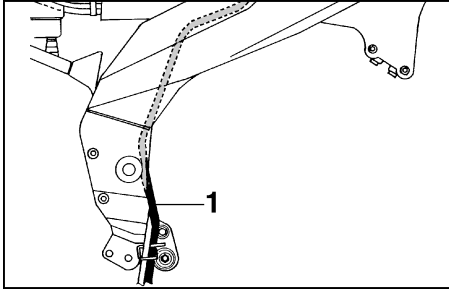

1. Fuel tank breather hose

EAU00196

Fuel tank breather hose (for Germany only)

This model is equipped with a fuel tank breather hose. Before using this motor-cycle, be sure to:

- Check hose connection.
- Check hose for cracks or damage. Replace if damaged.
- Make sure the end of the hose is not blocked. Clean it if necessary.

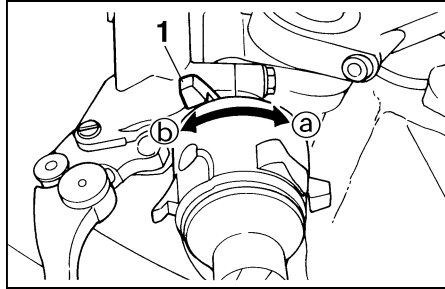

1. Starter (choke) “|↗|”

EAU02976

Starter (choke) “|↗|”

Starting a cold engine requires a richer air-fuel mixture. A separate starter circuit supplies this mixture.

Move in direction ① to turn on the starter (choke).

Move in direction ② to turn off the starter (choke).

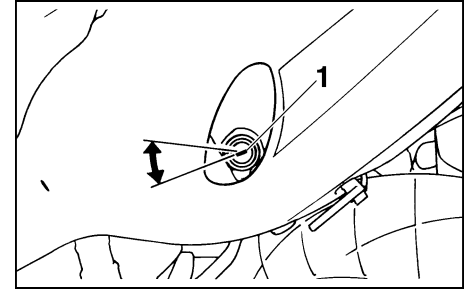

1. Rider seat lock

EAU01698*

Seats

Rider seat

To remove

Insert the key into the seat lock and turn it as shown.

INSTRUMENT AND CONTROL FUNCTIONS

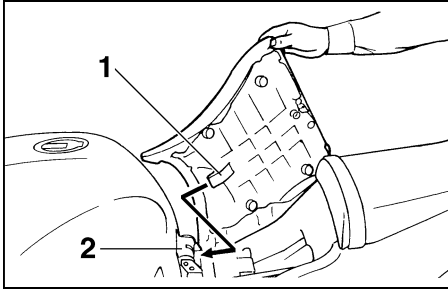

1. Projection
2. Seat holder

To install

Insert the projection on the front of the seat into the holder on the frame. Then push down on the seat.

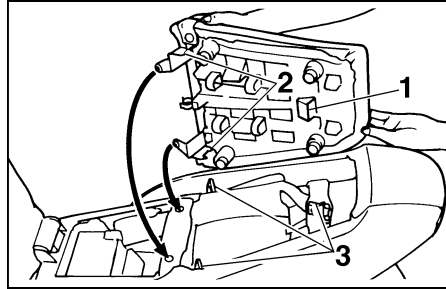

1. Projection
2. Hook (× 2)
3. Seat holder (× 3)

Passenger seat

To remove

Remove the rider seat. Then pull upward on the passenger seat.

To install

Insert the projection on the rear of the seat and the hooks on the front of the seat into the holders on the frame, and push the seat backward. Then install the rider seat.

NOTE: _____

Make sure that the seats are securely fitted.

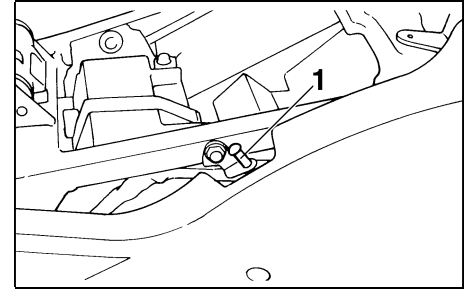

1. Helmet holder

EAU00264

Helmet holder

The helmet holder is located under the rider's seat. Remove the rider's seat and hook the helmet on the helmet holder. Then lock the seat.

EW000030



WARNING

Never ride with a helmet in the helmet holder. The helmet may hit objects, causing loss of control and possibly an accident.

INSTRUMENT AND CONTROL FUNCTIONS

3

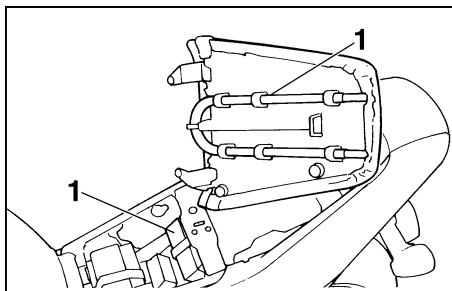

1. U-LOCK

EAU01688

Storage compartment

This compartment is designed to store a genuine Yamaha U-LOCK. (Other locks may not fit.) Be sure the lock is fastened securely with the straps when storing it in the compartment.

To prevent losing the straps, be sure to secure them even when a U-LOCK is not being stored in the compartment.

When storing this Owner's manual or other documents in the compartment, be sure to put them in a vinyl bag so they do not get wet. When washing the motorcycle, be careful not to flood this compartment with water.

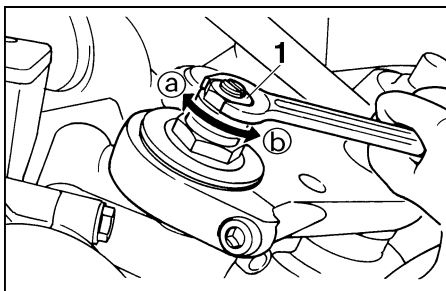

1. Spring preload adjusting bolt

EAU01862*

Front fork adjustment

This front fork is equipped with spring preload and damping force adjusters.

EW000037



Each fork leg must be set to the same pressure. Uneven setting can cause poor handling and loss of stability.

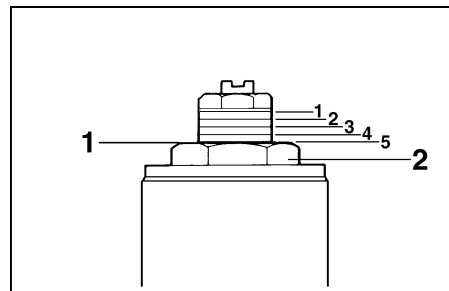

1. Setting
2. Front fork cap bolt

Adjusting spring preload

Turn the adjusting bolt in direction (a) to increase spring preload and in direction (b) to decrease spring preload. Align the preferred setting with the top of the front fork cap bolt.

INSTRUMENT AND CONTROL FUNCTIONS

EC000013

CAUTION: _____

The grooves are provided to show the adjustment level. Always keep the adjustment level equal on both fork legs.

	Hard			Standard	Soft
Adjusting position	1	2	3	4	5

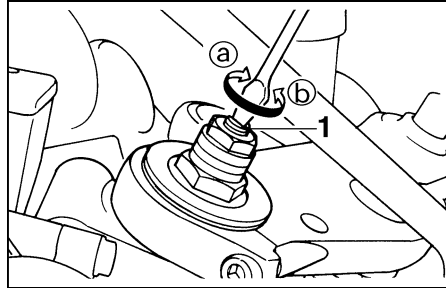

1. Rebound damping force adjusting screw

Adjusting rebound damping force

Turn the adjusting screw in direction ① to increase rebound damping force and in direction ② to decrease rebound damping force.

Minimum (soft)	25 clicks out*
Standard	9 clicks out*
Maximum (hard)	0 clicks out*

* From the fully turned-in position

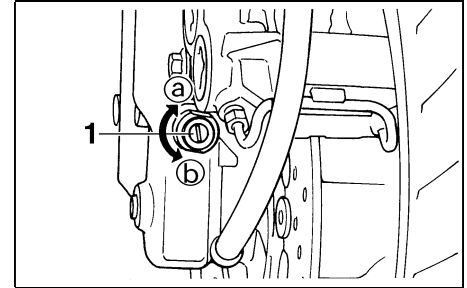

1. Compression damping force adjusting screw

Adjusting compression damping force

Turn the adjusting screw in direction ① to increase compression damping force and in direction ② to decrease compression damping force.

Minimum (soft)	25 clicks out*
Standard	12 clicks out*
Maximum (hard)	0 clicks out*

* From the fully turned-in position

INSTRUMENT AND CONTROL FUNCTIONS

EC000015

CAUTION: _____

Never attempt to turn an adjuster beyond the maximum or minimum setting.

NOTE: _____

Although the number of clicks between the minimum and maximum settings may vary with each individual shock absorber and may not exactly match these specifications, it is always the full damping force range that extends over the actual number of clicks.

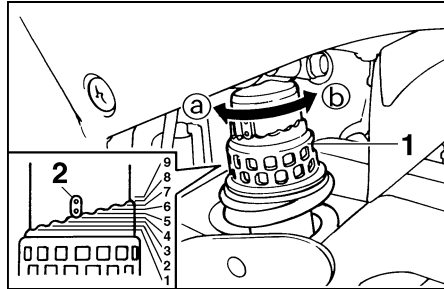

1. Spring preload adjusting ring
2. Position indicator

EAU01592*

Rear shock absorber adjustment

This shock absorber is equipped with spring preload and damping force adjusters.

EC000015

CAUTION: _____

Never attempt to turn an adjuster beyond the maximum or minimum setting.

Adjusting spring preload

Turn the adjusting ring in direction **a** to increase spring preload and in direction **b** to decrease spring preload.

Make sure that the appropriate notch in the adjusting ring is aligned with the position indicator on the rear shock absorber.

	Soft			Standard	Hard				
Adjusting position	1	2	3	4	5	6	7	8	9

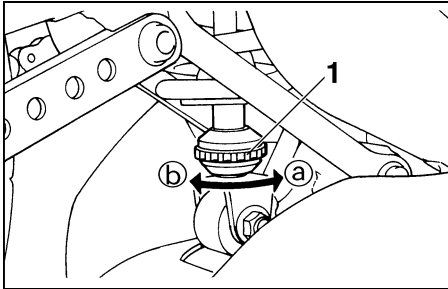

1. Rebound damping force adjuster

Adjusting rebound damping force

Turn the adjusting knob in direction ① to increase rebound damping force and in direction ② to decrease rebound damping force.

Minimum (soft)	20 clicks out*
Standard	10 clicks out*
Maximum (hard)	0 clicks out*

* From the fully turned-in position

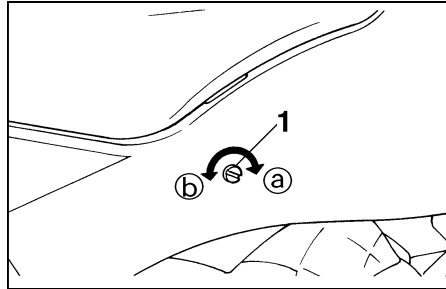

1. Compression damping force adjusting screw

Adjusting compression damping force

Turn the adjusting screw in direction ① to increase compression damping force and in direction ② to decrease compression damping force.

Minimum (soft):	0 clicks in*
Standard:	10 clicks in*
Maximum (hard):	24 clicks in*

* From the fully turned-out position

⚠ WARNING

This shock absorber contains highly pressurized nitrogen gas. Read and understand the following information before handling the shock absorber. The manufacturer cannot be held responsible for property damage or personal injury that may result from improper handling.

- Do not tamper with or attempt to open the cylinder assembly.
- Do not subject the shock absorber to an open flame or other high heat source. This may cause the unit to explode due to excessive gas pressure.
- Do not deform or damage the cylinder in any way. Cylinder damage will result in poor damping performance.
- Take your shock absorber to a Yamaha dealer for any service.

INSTRUMENT AND CONTROL FUNCTIONS

3

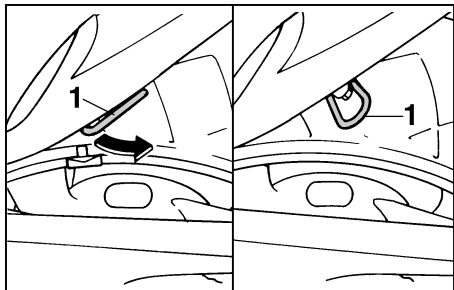

1. Luggage strap holder (× 4)

EAU00324

Luggage strap holders

There are four luggage strap holders below the passenger seat, two of which can be turned outward for easier access.

EAU01571

EXUP (EXhaust Ultimate Powervalue)

This model is equipped with Yamaha's EXUP system within the exhaust pipe. This valve is always activated by a computer-controlled servomotor in accordance with engine rpm.

EC000027

CAUTION:

- The EXUP was set at the Yamaha factory after many tests. If the settings are changed by someone without sufficient technical knowledge, poor engine performance and damage may result.
- If the EXUP does not operate, ask a Yamaha dealer to inspect.

EAU00330

Sidestand

This model is equipped with an ignition circuit cut-off system. The motorcycle must not be ridden when the sidestand is down. The sidestand is located on the left side of the frame. (Refer to page 5-1 for an explanation of this system.)

EW000044

! WARNING

This motorcycle must not be operated with the sidestand in the down position. If the stand is not properly retracted, it could contact the ground and distract the operator, resulting in a possible loss of control. Yamaha has designed into this motorcycle a lockout system to assist the operator in fulfilling the responsibility of retracting the sidestand. Please check carefully the operating instructions listed below and if there is any indication of a malfunction, return the motorcycle to a Yamaha dealer immediately for repair.

Sidestand/clutch switch operation check

EAU00331

Check the operation of the sidestand switch and clutch switch against the information below.

TURN THE MAIN SWITCH TO "ON" AND THE ENGINE STOP SWITCH TO "⊙".

TRANSMISSION IS IN GEAR AND SIDESTAND IS UP.

PULL IN CLUTCH LEVER AND PUSH THE START SWITCH.

ENGINE WILL START.

CLUTCH SWITCH IS OK.

SIDESTAND IS DOWN.

ENGINE WILL STALL.

SIDESTAND SWITCH IS OK.

EW000045

WARNING

If improper operation is noted, consult a Yamaha dealer immediately.

Pre-operation check list..... 4-1

PRE-OPERATION CHECKS

Owners are personally responsible for their vehicle's condition. Your motorcycle's vital functions can start to deteriorate quickly and unexpectedly, even if it remains unused (for instance, if it is exposed to the elements). Any damage, fluid leak or loss of tire pressure could have serious consequences. Therefore, it is very important that, in addition to a thorough visual inspection, you check the following points before each ride.

PRE-OPERATION CHECK LIST

ITEM	CHECKS	PAGE
Front brake	<ul style="list-style-type: none">• Check operation, free play, fluid level and fluid leakage.• Fill with DOT 4 brake fluid if necessary.	6-19 ~ 6-22
Rear brake		6-19 ~ 6-22
Clutch	<ul style="list-style-type: none">• Check operation, fluid level and fluid leakage.• Fill with DOT 4 brake fluid if necessary.	6-21 ~ 6-22
Throttle grip and housing	<ul style="list-style-type: none">• Check for smooth operation.• Lubricate if necessary.	6-15
Engine oil	<ul style="list-style-type: none">• Check oil level.• Fill with oil if necessary.	6-9 ~ 6-11
Coolant reservoir tank	<ul style="list-style-type: none">• Check coolant level.• Fill with coolant if necessary.	6-11 ~ 6-12
Drive chain	<ul style="list-style-type: none">• Check chain slack and condition.• Adjust if necessary.	6-23 ~ 6-24
Wheels and tires	<ul style="list-style-type: none">• Check tire pressure, wear and damage.	6-16 ~ 6-19
Control and meter cable	<ul style="list-style-type: none">• Check for smooth operation.• Lubricate if necessary.	6-24
Brake and shift pedal shafts	<ul style="list-style-type: none">• Check for smooth operation.• Lubricate if necessary.	6-24
Brake and clutch lever pivots	<ul style="list-style-type: none">• Check for smooth operation.• Lubricate if necessary.	6-25

PRE-OPERATION CHECKS

ITEM	CHECKS	PAGE
Sidestand pivot	<ul style="list-style-type: none">• Check for smooth operation.• Lubricate if necessary.	6-25
Chassis fasteners	<ul style="list-style-type: none">• Make sure that all nuts, bolts and screws are properly tightened.• Tighten if necessary.	—
Fuel	<ul style="list-style-type: none">• Check fuel level.• Fill with fuel if necessary.	3-11 ~ 3-12
Lights, signals and switches	<ul style="list-style-type: none">• Check for proper operation.	—

NOTE: _____
Pre-operation checks should be made each time the motorcycle is used. Such an inspection can be thoroughly accomplished in a very short time; and the added safety it assures is more than worth the time involved.

 **WARNING**

_____ **If any item in the PRE-OPERATION CHECK is not working properly, have it inspected and repaired before operating the motorcycle.**

OPERATION AND IMPORTANT RIDING POINTS

Starting the engine	5-1
Starting a warm engine	5-4
Shifting	5-4
Recommended shift points (for Switzerland only)	5-5
Tips for reducing fuel consumption	5-5
Engine break-in	5-5
Parking	5-6

EAU00373

EAU01627

! WARNING

- Before riding this motorcycle, become thoroughly familiar with all operating controls and their functions. Consult a Yamaha dealer regarding any control or function that you do not thoroughly understand.
- Never start your engine or let it run for any length of time in a closed area. The exhaust fumes are poisonous and can cause loss of consciousness and death within a short time. Always operate your motorcycle in an area with adequate ventilation.
- Before starting out, always be sure the sidestand is up. Failure to retract the sidestand completely can result in a serious accident when you try to turn a corner.

Starting the engine

NOTE:

This motorcycle is equipped with an ignition circuit cut-off system.

The engine can be started only under one of the following conditions:

- The transmission is in neutral.
- The sidestand is up, the transmission is in gear and the clutch is disengaged.

The motorcycle must not be ridden when the sidestand is down.

EW000054

! WARNING

Before going through the following steps, check the function of the sidestand switch and clutch switch. (Refer to page 3-20.)

OPERATION AND IMPORTANT RIDING POINTS

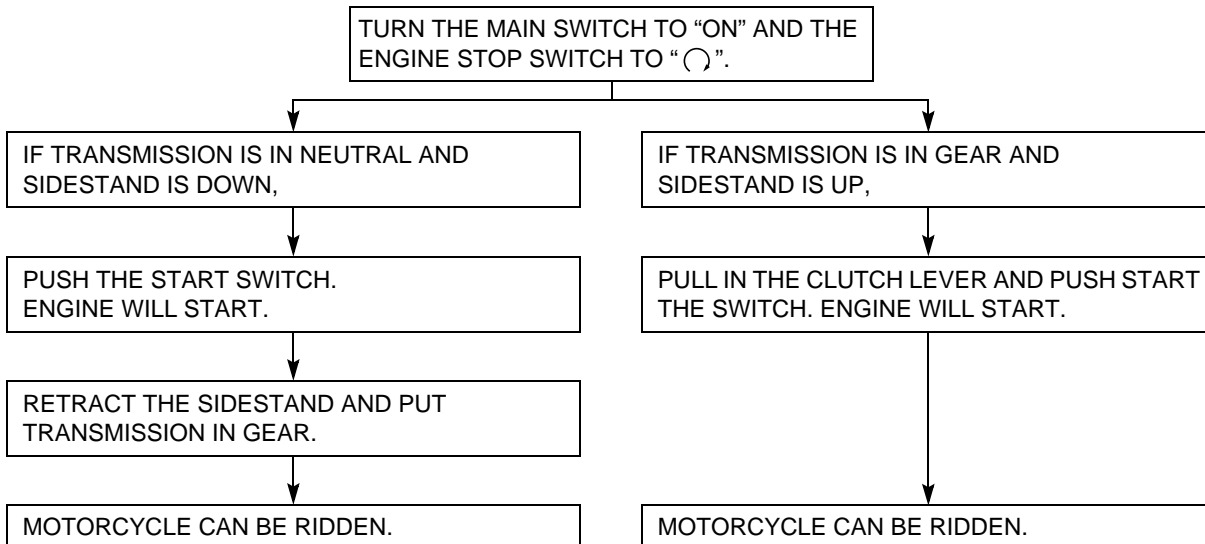

OPERATION AND IMPORTANT RIDING POINTS

1. Turn the main switch to “ON” and the engine stop switch to “

EC000035

CAUTION: _____

If the fuel indicator light comes on, check the fuel level. If necessary, fill the tank with fuel.

2. Shift the transmission into neutral.

NOTE: _____

When the transmission is in neutral, the neutral indicator light should be on. If the light does not come on, ask a Yamaha dealer to inspect it.

3. Turn on the starter (choke) and completely close the throttle grip.
4. Start the engine by pushing the start switch.

NOTE: _____

If the engine fails to start, release the start switch, wait a few seconds, then try again. Each attempt should be as short as possible to preserve the battery. Do not crank the engine more than 10 seconds on any one attempt.

EC000036

CAUTION: _____

The oil level indicator light and fuel indicator light should come on when the start switch is pushed and should go off when the start switch is released. If the oil level indicator light flickers or remains on, immediately stop the engine and check the engine oil level and for oil leakage. If necessary, fill the engine with oil and check to see that the oil level indicator light goes off. If not, consult a Yamaha dealer.

5. After starting the engine, move the starter (choke) to the halfway position.

NOTE: _____

For maximum engine life, never accelerate hard with a cold engine!

6. After the engine is warm, turn off the starter (choke) completely.

NOTE: _____

The engine is warm when it responds normally to the throttle with the starter (choke) turned off.

OPERATION AND IMPORTANT RIDING POINTS

Starting a warm engine

EAU01258

The starter (choke) is not required when the engine is warm.

EC000046

CAUTION:

See the “Engine break-in” section prior to operating the motorcycle for the first time.

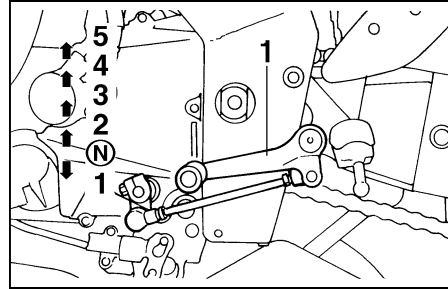

1. Shift pedal
N. Neutral

EAU00423

Shifting

The transmission lets you control the amount of power you have available at a given speed for starting, accelerating, climbing hills, etc. The use of the shift pedal is shown in the illustration.

To shift into neutral, depress the shift pedal repeatedly until it reaches the end of its travel, then raise the pedal slightly.

EC000048

CAUTION:

- Do not coast for long periods with the engine off, and do not tow the motorcycle a long distance. Even with gears in neutral, the transmission is only properly lubricated when the engine is running. Inadequate lubrication may damage the transmission.
- Always use the clutch when changing gears. The engine, transmission, and driveline are not designed to withstand the shock of forced shifting and can be damaged by shifting without using the clutch.

OPERATION AND IMPORTANT RIDING POINTS

EAU002941

Recommended shift points (for Switzerland only)

The recommended shift points are shown in the table below.

	Acceleration shift point (km/h)
1st → 2nd	23
2nd → 3rd	36
3rd → 4th	50
4th → 5th	60

NOTE:

When shifting two gears down from 4th to 2nd, bring your motorcycle to a speed of 35 km/h.

EAU00424

Tips for reducing fuel consumption

Your motorcycle's fuel consumption depends to a large extent on your riding style. The following tips can help reduce fuel consumption:

- Warm up the engine before riding.
- Turn off the starter (choke) as soon as possible.
- Shift up swiftly and avoid high engine speeds during acceleration.
- Do not double-clutch or rev the engine while shifting down and avoid high engine speeds with no load on the engine.
- Turn off the engine instead of letting it idle for an extended length of time, i.e. in traffic jams, at traffic lights or railroad crossings.

EAU00436

Engine break-in

There is never a more important period in the life of your motorcycle than the period between zero and 1,000 km. For this reason we ask that you carefully read the following material. Because the engine is brand new, you must not put an excessive load on it for the first 1,000 km. The various parts in the engine wear and polish themselves to the correct operating clearances. During this period, prolonged full throttle operation, or any condition which might result in excessive heating of the engine, must be avoided.

OPERATION AND IMPORTANT RIDING POINTS

0 ~ 150 km

EAU00440

Avoid operation above 5,000 r/min. Stop the engine and let it cool for 5 to 10 minutes after every hour of operation. Vary the speed of the motorcycle from time to time. Do not operate it at one set throttle position.

150 ~ 500 km

Avoid prolonged operation above 6,000 r/min. Rev the motorcycle freely through the gears, but do not use full throttle at any time.

500 ~ 1,000 km

Avoid prolonged full throttle operation. Avoid cruising speeds in excess of 7,000 r/min.

EC000052

CAUTION:

After 1,000 km of operation, be sure to replace the engine oil and oil filter.

1,000 km and beyond

Full throttle can be used.

EC000053

CAUTION:

- Never let engine speeds enter the red zone.
- If any engine trouble should occur during the break-in period, consult a Yamaha dealer immediately.

Parking

EAU00460

When parking the motorcycle, stop the engine and remove the ignition key.

EW000058

WARNING

The exhaust system is hot. Park the motorcycle in a place where pedestrians or children are not likely to touch the motorcycle. Do not park the motorcycle on a slope or soft ground; the motorcycle may overturn.

PERIODIC MAINTENANCE AND MINOR REPAIR

Tool kit.....	6-1	Drive chain slack adjustment	6-23
Periodic maintenance and lubrication.....	6-2	Drive chain lubrication.....	6-24
Cowling removal and installation	6-5	Cable inspection and lubrication	6-24
Cowling A.....	6-5	Brake and shift pedal lubrication	6-24
Cowling B.....	6-5	Brake and clutch lever lubrication	6-25
Cowling C	6-6	Sidestand lubrication.....	6-25
Spark plugs.....	6-7	Rear suspension lubrication.....	6-25
Engine oil.....	6-9	Front fork inspection.....	6-26
Coolant	6-11	Steering inspection	6-26
Air filter	6-12	Wheel bearings	6-27
Carburetor adjustment	6-14	Battery.....	6-27
Idle speed adjustment	6-15	Fuse replacement	6-28
Throttle cable free play inspection	6-15	Headlight bulb replacement	6-29
Valve clearance adjustment.....	6-16	Tail/brake light bulb replacement.....	6-30
Tires.....	6-16	Turn signal light bulb replacement.....	6-30
Wheels.....	6-19	Front wheel removal.....	6-31
Brake light switch adjustment	6-19	Front wheel installation	6-31
Checking the front and rear brake pads.....	6-20	Rear wheel removal	6-32
Inspecting the brake fluid level.....	6-21	Rear wheel installation	6-33
Brake fluid replacement	6-22	Troubleshooting.....	6-34
Drive chain slack check	6-23	Troubleshooting chart.....	6-35

Periodic inspection, adjustment and lubrication will keep your motorcycle in the safest and most efficient condition possible. Safety is an obligation of the motorcycle owner. The maintenance and lubrication schedule chart should be considered strictly as a guide to general maintenance and lubrication intervals. YOU MUST TAKE INTO CONSIDERATION THAT WEATHER, TERRAIN, GEOGRAPHICAL LOCATIONS, AND A VARIETY OF INDIVIDUAL USES ALL TEND TO DEMAND THAT EACH OWNER ALTER THIS TIME SCHEDULE TO SHORTER INTERVALS TO MATCH THE ENVIRONMENT. The most important points of motorcycle inspection, adjustment, and lubrication are explained in the following pages.

EAU00464

EW000060

! WARNING

If you are not familiar with motorcycle service, this work should be done by a Yamaha dealer.

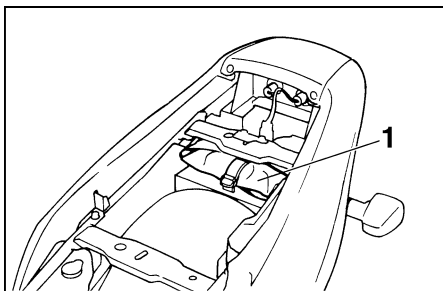

1. Tool kit

EAU00469

Tool kit

The service information included in this manual is intended to provide you, the owner, with the necessary information for completing some of your own preventive maintenance and minor repairs. The tools provided in the owner's tool kit are to assist you in the performance of periodic maintenance. However, some other tools such as a torque wrench are also necessary to perform the maintenance correctly.

NOTE:

If you do not have necessary tools required during a service operation, take your motorcycle to a Yamaha dealer for service.

EW000063

! WARNING

Modifications to this motorcycle not approved by Yamaha may cause loss of performance, and render it unsafe for use. Consult a Yamaha dealer before attempting any changes.

PERIODIC MAINTENANCE AND MINOR REPAIR

EAU00473

PERIODIC MAINTENANCE AND LUBRICATION

NO.	ITEM	CHECKS AND MAINTENANCE JOBS	INITIAL (1,000 km)	EVERY	
				6,000 km or 6 months (whichever comes first)	12,000 km or 12 months (whichever comes first)
1	* Fuel line	<ul style="list-style-type: none"> • Check fuel hoses and vacuum hose for cracks or damage. • Replace if necessary. 		√	√
2	* Fuel filter	<ul style="list-style-type: none"> • Check condition. • Replace if necessary. 			√
3	Spark plugs	<ul style="list-style-type: none"> • Check condition. • Clean, regap or replace if necessary. 	√	√	√
4	* Valves	<ul style="list-style-type: none"> • Check valve clearance. • Adjust if necessary. 	Every 42,000 km or 42 months (whichever comes first)		
5	Air filter	<ul style="list-style-type: none"> • Clean or replace if necessary. 		√	√
6	* Clutch	<ul style="list-style-type: none"> • Check operation, fluid level and vehicle for fluid leakage. (See NOTE on page 6-4.) • Correct accordingly. 	√	√	√
7	* Front brake	<ul style="list-style-type: none"> • Check operation, fluid level and vehicle for fluid leakage. (See NOTE on page 6-4.) • Correct accordingly. • Replace brake pads if necessary. 	√	√	√
8	* Rear brake	<ul style="list-style-type: none"> • Check operation, fluid level and vehicle for fluid leakage. (See NOTE on page 6-4.) • Correct accordingly. • Replace brake pads if necessary. 	√	√	√
9	* Wheels	<ul style="list-style-type: none"> • Check balance, runout and for damage. • Rebalance or replace if necessary. 		√	√
10	* Tires	<ul style="list-style-type: none"> • Check tread depth and for damage. • Replace if necessary. • Check air pressure. • Correct if necessary. 		√	√

PERIODIC MAINTENANCE AND MINOR REPAIR

NO.	ITEM	CHECKS AND MAINTENANCE JOBS	INITIAL (1,000 km)	EVERY	
				6,000 km or 6 months (whichever comes first)	12,000 km or 12 months (whichever comes first)
11	* Wheel bearings	<ul style="list-style-type: none"> • Check bearing for looseness or damage. • Replace if necessary. 		√	√
12	* Swingarm	<ul style="list-style-type: none"> • Check swingarm pivoting point for play. • Correct if necessary. • Lubricate with molybdenum disulfide grease every 24,000 km or 24 months (whichever comes first). 		√	√
13	Drive chain	<ul style="list-style-type: none"> • Check chain slack. • Adjust if necessary. Make sure that the rear wheel is properly aligned. • Clean and lubricate. 	Every 1,000 km and after washing the motorcycle or riding in the rain		
14	* Steering bearings	<ul style="list-style-type: none"> • Check bearing play and steering for roughness. • Correct accordingly. • Lubricate with lithium soap base grease every 24,000 km or 24 months (whichever comes first). 		√	√
15	* Chassis fasteners	<ul style="list-style-type: none"> • Make sure that all nuts, bolts and screws are properly tightened. • Tighten if necessary. 		√	√
16	Sidestand	<ul style="list-style-type: none"> • Check operation. • Lubricate and repair if necessary. 		√	√
17	* Sidestand switch	<ul style="list-style-type: none"> • Check operation. • Replace if necessary. 	√	√	√
18	* Front fork	<ul style="list-style-type: none"> • Check operation and for oil leakage. • Correct accordingly. 		√	√
19	* Rear shock absorber assembly	<ul style="list-style-type: none"> • Check operation and shock absorber for oil leakage. • Replace shock absorber assembly if necessary. 		√	√
20	* Rear suspension relay arm and connecting arm pivoting points	<ul style="list-style-type: none"> • Check operation. • Lubricate with molybdenum disulfide grease every 24,000 km or 24 months (whichever comes first). 		√	√
21	* Carburetors	<ul style="list-style-type: none"> • Check engine idling speed, synchronization and starter operation. • Adjust if necessary. 	√	√	√

PERIODIC MAINTENANCE AND MINOR REPAIR

NO.	ITEM	CHECKS AND MAINTENANCE JOBS	INITIAL (1,000 km)	EVERY	
				6,000 km or 6 months (whichever comes first)	12,000 km or 12 months (whichever comes first)
22	Engine oil	<ul style="list-style-type: none"> • Check oil level and vehicle for oil leakage. • Correct if necessary. • Change. (Warm engine before draining.) 	√	√	√
23	Engine oil filter cartridge	<ul style="list-style-type: none"> • Replace. 	√		√
24	* Cooling system	<ul style="list-style-type: none"> • Check coolant level and vehicle for coolant leakage. • Correct if necessary. • Change coolant every 24,000 km or 24 months (whichever comes first). 		√	√

* Since these items require special tools, data and technical skills, they should be serviced by a Yamaha dealer.

EAU02971*

NOTE:

- The air filter needs more frequent service if you are riding in unusually wet or dusty areas.
- Hydraulic brake and clutch systems
 - After disassembling the master cylinder, caliper cylinder or clutch release cylinder, always replace the brake fluid. Check the brake fluid level of the master cylinder and clutch release cylinder regularly and fill as required.
 - Replace the oil seals on the inner parts of the master cylinder, caliper cylinder and clutch release cylinder every two years.
 - Replace the brake and clutch hoses every four years or if cracked or damaged.

PERIODIC MAINTENANCE AND MINOR REPAIR

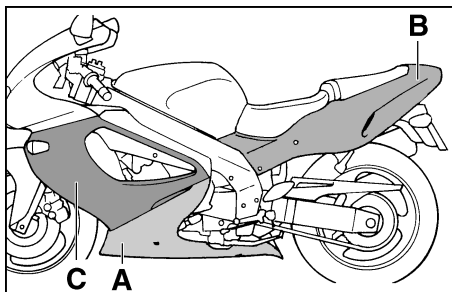

EAU01065

Cowling removal and installation

The cowlings indicated in the illustration need to be removed to perform some of the maintenance described in this chapter. Refer to this section each time a cowling has to be removed or re-installed.

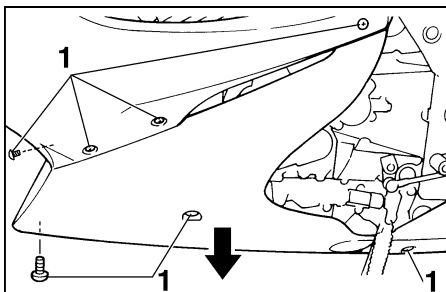

EAU00484*

Cowling A

To remove

Remove the screws and pull outward as shown.

To install

Place in the original position and install the screws.

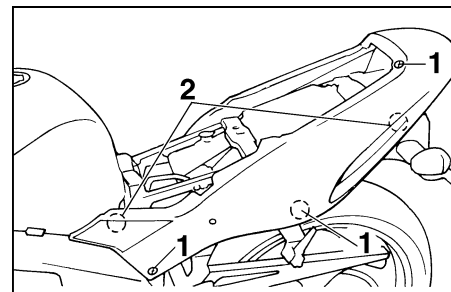

EAU00482

Cowling B

To remove

Remove the screws.

PERIODIC MAINTENANCE AND MINOR REPAIR

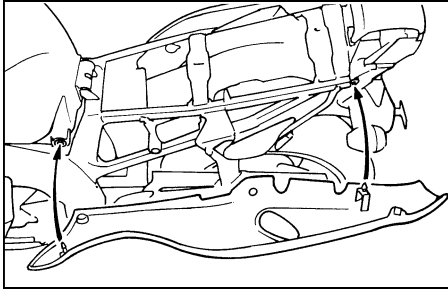

To install

Place in the original position and install the screws.

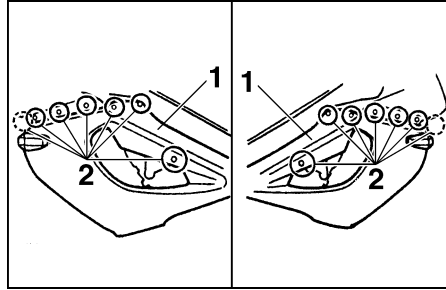

1. Cowling C
2. Bolt (× 14)

Cowling C

To remove

Remove the bolts shown and disconnect the turn signal leads.

EAU00483

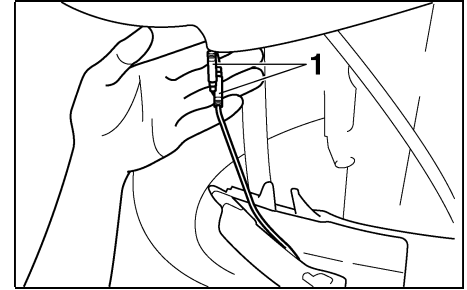

1. Turn signal lead (× 2)

To install

Place in the original position, install the bolts and connect the turn signal leads.

PERIODIC MAINTENANCE AND MINOR REPAIR

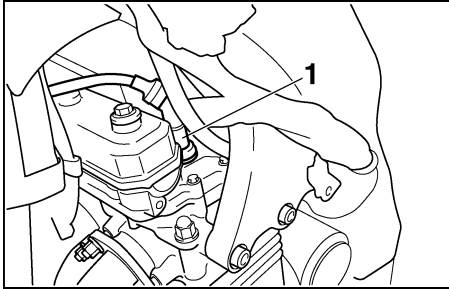

1. Spark plug cap (× 4)

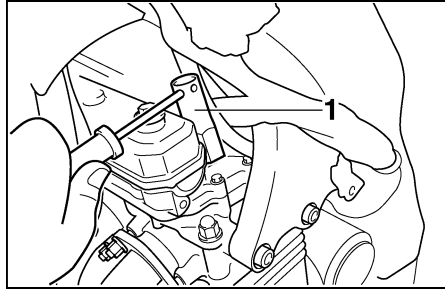

1. Spark plug wrench

Spark plugs

Removal

1. Remove cowlings A and C. (See pages 6-5 and 6-6 for removal and installation procedures.)
2. Remove the spark plug caps.

EAU01668*

3. Use the spark plug wrench in the tool kit to remove the spark plugs as shown.

Inspection

The spark plug is an important engine component and is easy to inspect. The condition of the spark plug can indicate the condition of the engine.

Normally, all spark plugs from the same engine should have the same color on the white insulator around the center electrode. The ideal color at this point is a medium-to-light tan color for a motorcycle that is being ridden normally. If one spark plug shows a distinctly

different color, there could be something wrong with the engine.

Do not attempt to diagnose such problems yourself. Instead, take the motorcycle to a Yamaha dealer. You should periodically remove and inspect the spark plugs because heat and deposits will cause any spark plug to slowly break down and erode. If electrode erosion becomes excessive, or if carbon and other deposits are excessive, you should replace the spark plug with the specified plug.

Specified spark plug:
DR8EA (NGK)
X24ESR-U (DENSO)

PERIODIC MAINTENANCE AND MINOR REPAIR

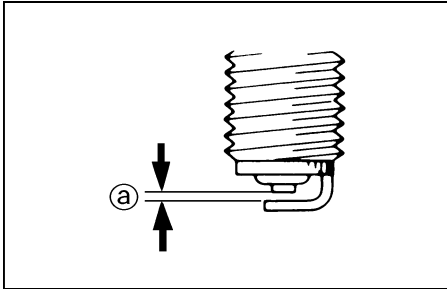

a. Spark plug gap

Tightening torque:
Spark plug:
18 Nm (1.8 m·kg)

NOTE: _____
If a torque wrench is not available when you are installing a spark plug, a good estimate of the correct torque is 1/4 to 1/2 turn past finger tight. Have the spark plug tightened to the specified torque as soon as possible.

Installation

1. Measure the electrode gap with a wire thickness gauge and, if necessary, adjust the gap to specification.
2. Clean the gasket surface. Wipe off any grime from the threads.
3. Install the spark plugs and tighten them to the specified torque.

Spark plug gap:
0.6 ~ 0.7 mm

4. Install the spark plug caps.
5. Install the cowlings.

PERIODIC MAINTENANCE AND MINOR REPAIR

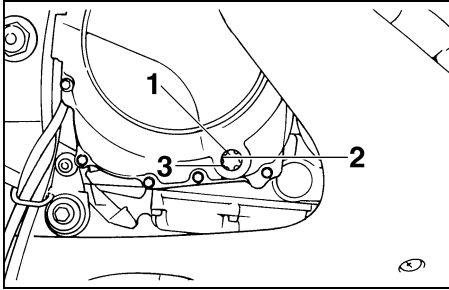

1. Oil level window
2. Maximum level mark
3. Minimum level mark

EAU01765*

Engine oil

Oil level inspection

1. Place the motorcycle on a level place and hold it in an upright position. Warm up the engine for several minutes.

NOTE: _____
Be sure the motorcycle is positioned straight up when checking the oil level. A slight tilt toward the side can result in false readings.

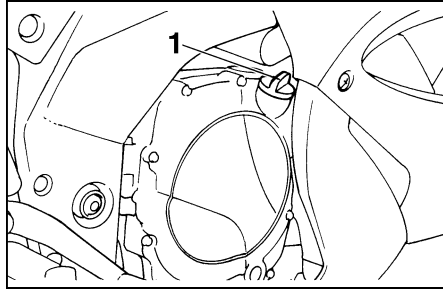

1. Engine oil filler cap
2. With the engine stopped, check the oil level through the level window located at the lower part of the right side crankcase cover.

NOTE: _____
Wait a few minutes until the oil level settles before checking.

3. The oil level should be between maximum and minimum marks. If the level is low, fill the engine with sufficient oil to reach the specified level.

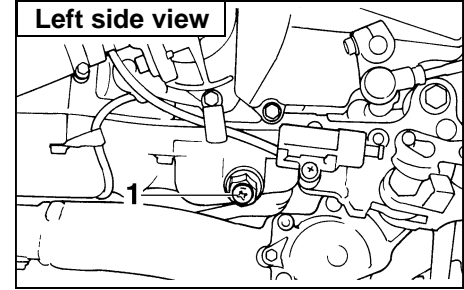

1. Engine oil drain bolt

Engine oil and oil filter cartridge replacement

1. Remove cowling A. (See page 6-5 for removal and installation procedures.)
2. Warm up the engine for several minutes.
3. Stop the engine. Place an oil pan under the engine and remove the oil filler cap.
4. Remove the drain bolt and drain the oil.

PERIODIC MAINTENANCE AND MINOR REPAIR

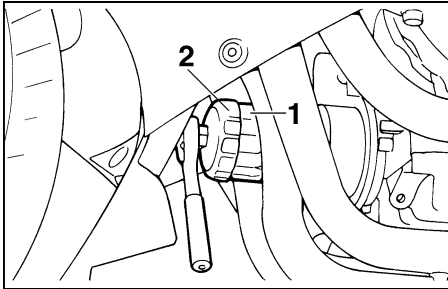

- 1. Oil filter
- 2. Oil filter wrench

5. Remove the oil filter by using an oil filter wrench.

NOTE: _____
An oil filter wrench is available at a nearby Yamaha dealer.

6. Reinstall the drain bolt and tighten it to the specified torque.

Tightening torque:
Drain bolt:
43 Nm (4.3 m·kg)

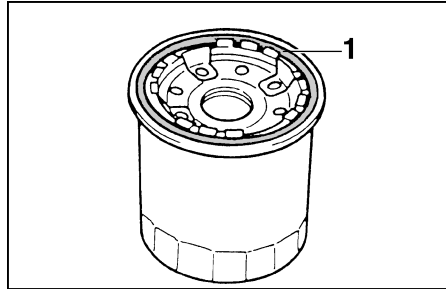

- 1. O-ring

7. Apply a light coat of engine oil to the O-ring of the new oil filter.

NOTE: _____
Make sure the O-ring is seated properly.

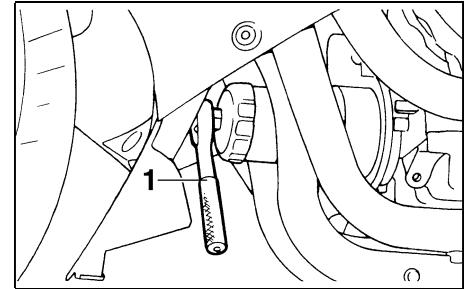

- 1. Torque wrench

8. Install the oil filter and tighten it to the specified torque with an oil filter wrench.

NOTE: _____
When installing the oil filter, tighten it to the proper torque by using a torque wrench.

Tightening torque:
Oil filter:
17 Nm (1.7 m·kg)

9. Fill the engine with sufficient oil to reach the specified level. Install the oil filler cap and tighten it.

PERIODIC MAINTENANCE AND MINOR REPAIR

Recommended oil:

See page 8-1.

Oil quantity:

Total amount:

3.5 L

Periodic oil change:

3.0 L

With oil filter replacement:

3.2 L

EC000066

CAUTION:

- Do not put in any chemical additives. Engine oil also lubricates the clutch and additives could cause clutch slippage.
- Be sure no foreign material enters the crankcase.

10. Start the engine and warm it up for several minutes. While warming up, check for oil leakage. If oil leakage is found, stop the engine immediately and check for the cause.

NOTE:

After the engine is started, the oil level indicator light should go off if the oil is at the specified level.

EC000067

CAUTION:

If the indicator light flickers or remains on, immediately stop the engine and consult with a Yamaha dealer.

11. Install the cowlng stay and cowlng.

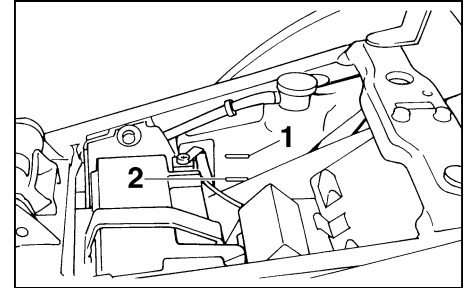

1. Maximum level mark

2. Minimum level mark

EAU01594

Coolant

Check the coolant level in the reservoir tank when the engine is cold. The coolant level will vary with engine temperature. The coolant level is satisfactory if it is between the minimum and maximum marks on the tank. If the coolant level is at or below the minimum mark, fill with tap water (soft water) to bring the level up to the maximum mark. Have a Yamaha dealer change the coolant every two years.

PERIODIC MAINTENANCE AND MINOR REPAIR

EW000067

! WARNING

Do not remove the radiator cap when the engine is hot.

EC000080

CAUTION:

Hard water or salt water is harmful to the engine. You may use distilled water if you can't get soft water.

Reservoir tank capacity:
0.23 L

NOTE:

The radiator fan operation is completely automatic. It is switched on or off according to the coolant temperature in the radiator.

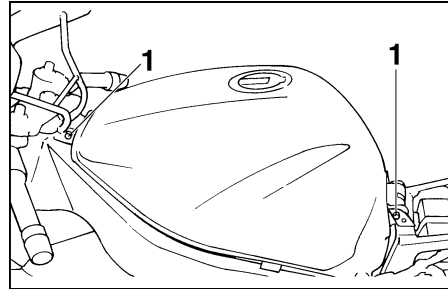

1. Bolt (x 2)

EAU01332

Air filter

The air filter should be cleaned at the specified intervals. It should be cleaned more frequently if you are riding in unusually wet or dusty areas.

1. Remove the seats.
2. Remove cowling B from each side. (See page 6-5.)
3. Remove the bolts holding the fuel tank.
4. Lift the fuel tank upward and position it away from the air filter case. (Do not remove the fuel hoses.)

EW000071

! WARNING

- Support the fuel tank carefully during this procedure.
- Do not tilt the fuel tank too much or pull it too hard because the fuel hose connections may become loose causing fuel leakage.

PERIODIC MAINTENANCE AND MINOR REPAIR

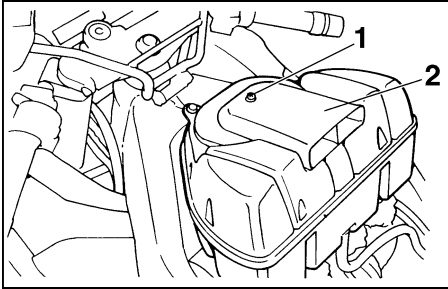

1. Screw
2. Air filter case cover

5. Remove the screw holding the air filter case cover.
6. Pull out the air filter.

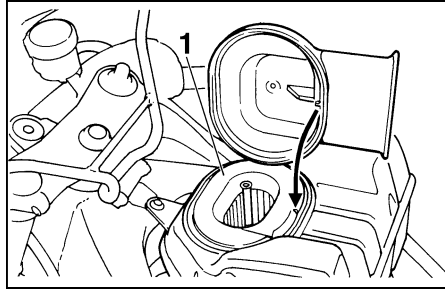

1. Air filter

7. Tap the air filter lightly to remove most of the dust and dirt. Blow out the remaining dirt with compressed air as shown. If the air filter is damaged, replace it.
8. Reinstall by reversing the removal procedure.

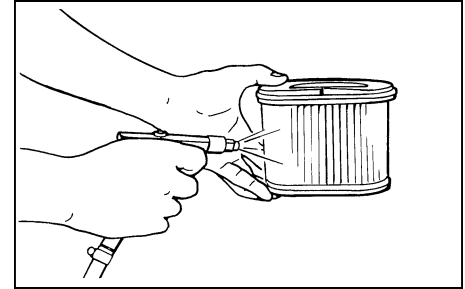

EC000082

CAUTION:

- Make sure the air filter is properly seated in the air filter case.
- The engine should never be run without the air filter installed. Excessive piston and/or cylinder wear may result.

EW000072

EAU00630

WARNING

- Before reinstallation, make sure that the fuel hoses are not damaged at all. If any damage is found, it may result in a fuel leak, so do not start the engine. Ask a Yamaha dealer for repairs.
- Always make sure that the fuel hoses are properly connected, in place, and not pinched.

Carburetor adjustment

The carburetors are important parts of the engine and require very sophisticated adjustment. Most adjustments should be left to a Yamaha dealer who has the professional knowledge and experience to do so. However, the idle speed may be adjusted by the owner as part of routine maintenance.

EC000095

CAUTION:

The carburetors were set at the Yamaha factory after many tests. If they are changed, poor engine performance and damage may result.

PERIODIC MAINTENANCE AND MINOR REPAIR

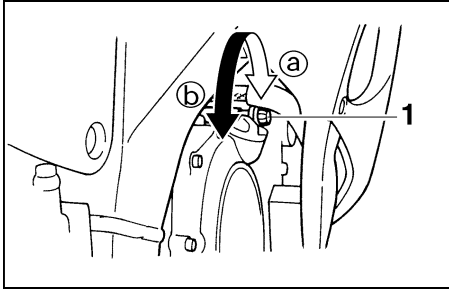

1. Throttle stop screw

EAU00632

Idle speed adjustment

1. Start the engine and warm it up for a few minutes at approximately 1,000 to 2,000 r/min. Occasionally rev the engine to 4,000 to 5,000 r/min. The engine is warm when it quickly responds to the throttle.
2. Set the idle to the specified engine speed by adjusting the throttle stop screw. Turn the screw in direction **a** to increase engine speed and in direction **b** to decrease engine speed.

Standard idle speed:

1,100 r/min (except for F, S, SF, D)

1,050 r/min (for F, S, SF, D)

NOTE: _____
If the specified idle speed cannot be obtained by performing the above adjustment, consult a Yamaha dealer.

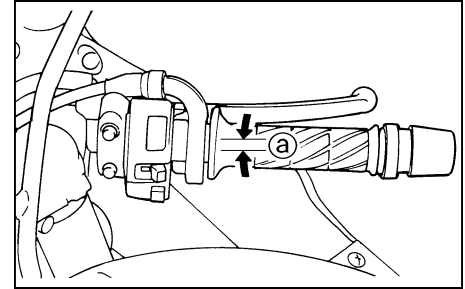

a. Free play

EAU00635

Throttle cable free play inspection

There should be a free play of 3 ~ 7 mm at the throttle grip. If the free play is incorrect, ask a Yamaha dealer to make this adjustment.

PERIODIC MAINTENANCE AND MINOR REPAIR

Valve clearance adjustment

EAU00637

The correct valve clearance changes with use, resulting in improper fuel/air supply or engine noise. To prevent this, the valve clearance must be adjusted regularly. This adjustment however, should be left to a professional Yamaha service technician.

Tires

To ensure maximum performance, long service and safe operation, note the following:

Tire air pressure

Always check and adjust the tire pressure before operating the motorcycle.

EAU00658

EW000082



Tire inflation pressure should be checked and adjusted when the temperature of the tire equals the ambient air temperature. Tire inflation pressure must be adjusted according to total weight of cargo, rider, passenger, and accessories (fairing, saddlebags, etc. if approved for this model), and vehicle speed.

Maximum load*	196 kg	
Cold tire pressure	Front	Rear
Up to 90 kg load*	250 kPa (2.50 kg/cm ² , 2.50 bar)	250 kPa (2.50 kg/cm ² , 2.50 bar)
90 kg Maximum load*	290 kPa (2.90 kg/cm ² , 2.90 bar)	290 kPa (2.90 kg/cm ² , 2.90 bar)
High speed riding	290 kPa (2.90 kg/cm ² , 2.90 bar)	290 kPa (2.90 kg/cm ² , 2.90 bar)

* Load is the total weight of cargo, rider, passenger and accessories.

PERIODIC MAINTENANCE AND MINOR REPAIR

EW000083

⚠ WARNING

Proper loading of your motorcycle is important for several characteristics of your motorcycle, such as handling, braking, performance and safety. Do not carry loosely packed items that can shift. Securely pack your heaviest items close to the center of the motorcycle, and distribute the weight evenly from side to side. Properly adjust the suspension for your load, and check the condition and pressure of your tires. **NEVER OVERLOAD YOUR MOTORCYCLE.** Make sure the total weight of the cargo, rider, passenger, and accessories (fairing, saddlebags, etc. if approved for this model) does not exceed the maximum load of the motorcycle. Operation of an overloaded motorcycle could cause tire damage, an accident, or even injury.

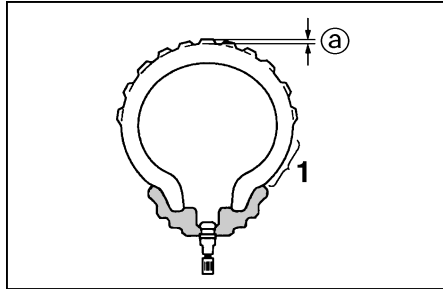

- 1. Side wall
- a. Tread depth

Tire inspection

Always check the tires before operating the motorcycle. If center tread depth reaches the limit as shown, if the tire has a nail or glass fragments in it, or if the side wall is cracked, contact a Yamaha dealer immediately and have the tire replaced.

EW000095

⚠ WARNING

Operating the motorcycle with excessively worn tires decrease riding stability and can lead to loss of control. Have excessively worn tires replaced by a Yamaha dealer immediately. Brakes, tires, and related wheel parts replacement should be left to a Yamaha Service Technician.

Minimum tire tread depth (front and rear)	1.6 mm
--	--------

NOTE:

These limits may be different by regulation from country to country. If so, conform to the limits specified by the regulations of your own country.

Tire information

This motorcycle is equipped with tubeless tires, tire valves and cast wheels.

PERIODIC MAINTENANCE AND MINOR REPAIR

EW000080

⚠ WARNING

- After extensive tests, the tires mentioned below have been approved by Yamaha Motor Co., Ltd. for this model. No guarantee for handling characteristics can be given if tire combinations other than what is approved are used on this motorcycle. The front and rear tires should be of the same manufacture and design.
- The use of tire valves and valve cores other than listed below could cause tire deflation during extreme high speed riding. Always use genuine parts or their equivalent for replacement.
- Be sure to install the valve caps securely, as these are important to prevent air pressure leakage during extreme high speed riding.

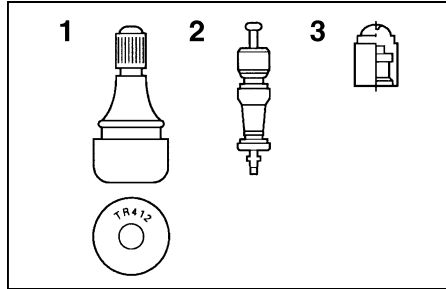

1. Tire valve
2. Valve core
3. Valve cap with seal

FRONT

Manufacturer	Size	Type
Bridgestone	120/70 ZR17	BT50F
Dunlop	120/70 ZR17	D204FN
Michelin	120/70 ZR17	MACADAM 90XM
Metzeler	120/70 ZR17	MEZ1
Metzeler	120/70 ZR17	MEZ2

REAR

Manufacturer	Size	Type
Bridgestone	180/55 ZR17	BT50R
Dunlop	180/55 ZR17	D204M
Michelin	180/55 ZR17	MACADAM 90XM
Metzeler	180/55 ZR17	MEZ1
Metzeler	180/55 ZR17	MEZ2

	Type
Tire valve	TR412
Valve core	#9000A (original)

PERIODIC MAINTENANCE AND MINOR REPAIR

EAU00684

EAU00687

⚠ WARNING

This motorcycle is fitted with super high-speed running tires. The following points must be observed in order for you to make fully effective use of these tires.

- Never fail to use the specified tires in tire replacement. Other tires may have a danger of bursting at super high-speeds.
- New tires have a relatively low grip on the road surface until they have been slightly worn. Therefore, approximately 100 km should be traveled at normal speed before any high-speed riding is done.
- Before any high-speed runs, the tires should be warmed-up sufficiently.
- Always inflate to the correct tire pressure according to the operating conditions.

Wheels

To ensure maximum performance, long service, and safe operation, note the following:

- Always inspect the wheels before a ride. Check for cracks, bends, or warpage of the wheels. If any abnormal condition exists in a wheel, consult a Yamaha dealer. Do not attempt even small repairs to the wheel. If a wheel is deformed or cracked, it must be replaced.
- Tires and wheels should be balanced whenever either one is changed or replaced. Failure to have a wheel balanced can result in poor performance, adverse handling characteristics, and shortened tire life.
- Ride at moderate speeds after changing a tire since the tire surface must first be broken in for it to develop its optimal characteristics.

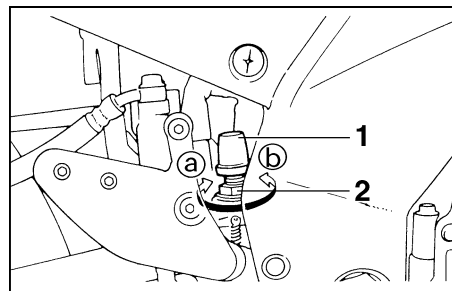

1. Brake light switch
2. Adjusting nut

EAU00713

Brake light switch adjustment

The rear brake light switch is activated by the brake pedal and is properly adjusted when the brake light comes on just before braking takes effect. To adjust the rear brake light switch, hold the switch body so it does not rotate while turning the adjusting nut.

Turn the adjusting nut in direction **a** to make the brake light come on earlier. Turn the adjusting nut in direction **b** to make the brake light come on later.

PERIODIC MAINTENANCE AND MINOR REPAIR

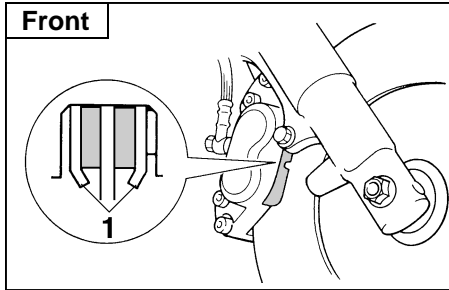

1. Wear indicator

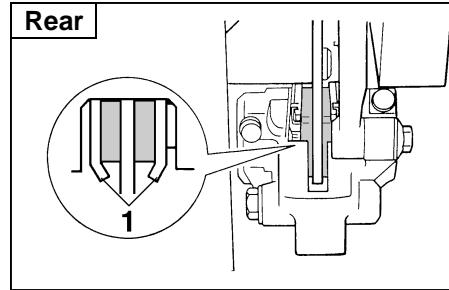

1. Wear indicator

EAU00715

Checking the front and rear brake pads

A wear indicator is provided on each brake. This indicator allows checking of brake pad wear without disassembling the brake. Apply the brake and inspect the wear indicator. If the indicator is ALMOST in contact with the disc plate, ask a Yamaha dealer to replace the pads.

PERIODIC MAINTENANCE AND MINOR REPAIR

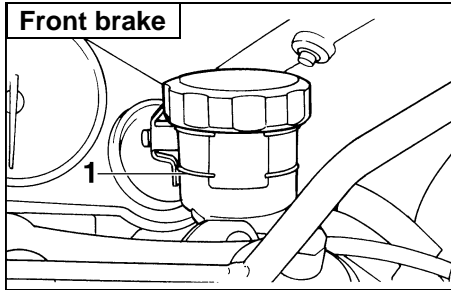

1. Minimum level mark

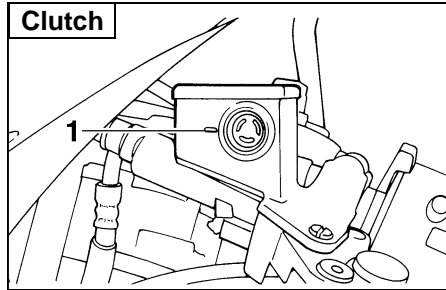

1. Minimum level mark

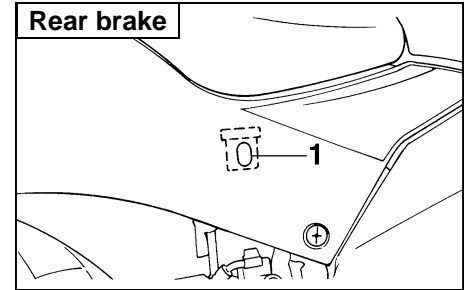

1. Minimum level mark

Inspecting the brake fluid level

EAU01800

Insufficient brake fluid may let air enter the brake or clutch system, possibly causing them to become ineffective.

Before riding, check that the brake fluid is above the minimum level and fill when necessary. Low brake fluid levels may indicate worn brake pads and/or brake system leakage. If the brake level is low, be sure to inspect the brake pads for wear or brake system for leakage.

Observe these precautions:

- When checking the fluid level, make sure the top of the master cylinder is level by turning the handlebars.
- Use only the designated quality brake fluid. Otherwise, the rubber seals may deteriorate, causing leakage and poor brake or clutch performance.

Recommended brake fluid: DOT 4

- Refill with the same type of brake fluid. Mixing fluids may result in a harmful chemical reaction and lead to poor brake or clutch performance.

PERIODIC MAINTENANCE AND MINOR REPAIR

EAU00742

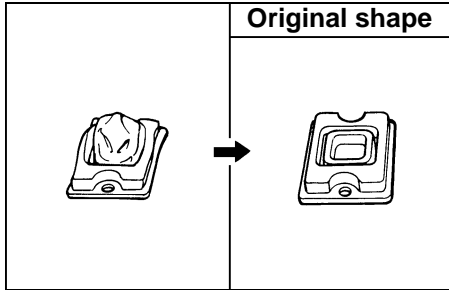

- Be careful that water does not enter the master cylinder when refilling. Water will significantly lower the boiling point of the fluid and may result in vapor lock.

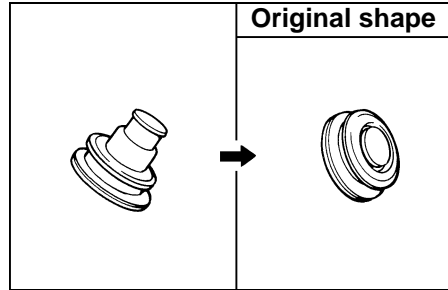

- Brake fluid may deteriorate painted surfaces or plastic parts. Always clean up spilled fluid immediately.
- Have a Yamaha dealer check the cause if the brake fluid level goes down.

Brake fluid replacement

The brake fluid should be replaced only by trained Yamaha service personnel. Have the Yamaha dealer replace the following components during periodic maintenance or when they are damaged or leaking:

- oil seals (every two years)
- brake hoses (every four years)

PERIODIC MAINTENANCE AND MINOR REPAIR

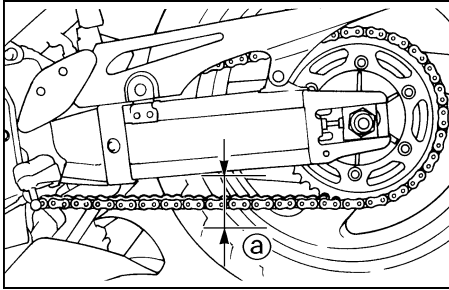

a. Drive chain slack

EAU00744

Drive chain slack check

NOTE:

Spin the wheel several times and find the tightest position of the chain. Check and/or adjust the chain slack while it's in this tightest position.

To check the chain slack the motorcycle must be held straight up with both wheels on the ground and without rider. Check the slack at the position shown in the illustration. Normal slack is approximately 20 ~ 35 mm. If the slack exceeds 35 mm, adjust.

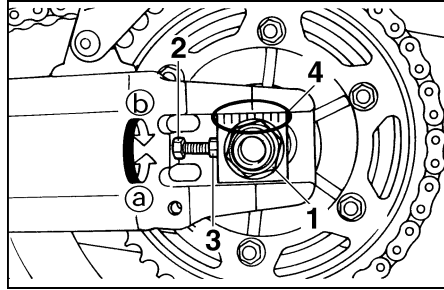

1. Axle nut
2. Adjusting bolt
3. Locknut
4. Alignment marks

EAU01251

Drive chain slack adjustment

1. Loosen the axle nut.
2. Loosen the locknuts on each side.
To tighten the chain, turn the chain adjusting bolts in direction ①. To loosen the chain, turn the adjusting bolts in direction ② and push the wheel forward. Turn each adjusting bolt exactly the same amount to maintain correct axle alignment. There are marks on

each side of the swingarm. Use these marks to align the rear wheel.

EC000096

CAUTION:

Too little chain slack will overload the engine and other vital parts. Keep the slack within the specified limits.

3. After adjusting, tighten the locknuts. Then tighten the axle nut to the specified torque.

Tightening torque:

Axle nut:

150 Nm (15 m·kg)

PERIODIC MAINTENANCE AND MINOR REPAIR

Drive chain lubrication

EAU03006

The chain consists of many parts which work with each other. If the chain is not maintained properly, it will wear out quickly. Therefore, the chain must be serviced regularly. This service is especially necessary when riding in dusty areas. This motorcycle is equipped with a sealed type chain. Steam cleaning, high-pressure washers, and solvents can damage the drive chain, so do not use these for cleaning it. Use only kerosene to clean the drive chain. Wipe it dry, and thoroughly lubricate it with SAE 30 ~ 50W motor oil. Do not use any other lubricants on the drive chain. They may contain solvents that could damage the sealed chain.

EC000097

CAUTION:

Be sure to oil the chain after washing the motorcycle or riding in the rain.

Cable inspection and lubrication

EAU02962

EW000112

⚠ WARNING

Damage to the outer housing of cables may lead to internal rusting and interfere with the cable movement. Replace damaged cables as soon as possible to prevent unsafe conditions.

Lubricate the cables and cable ends. If a cable does not operate smoothly, ask a Yamaha dealer to replace it.

Recommended lubricant:
Engine oil

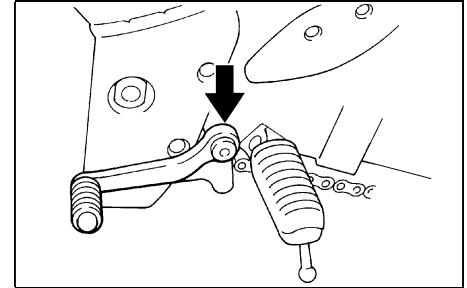

EAU02984

Brake and shift pedal lubrication

Lubricate the pivoting parts.

Recommended lubricant:
Engine oil

PERIODIC MAINTENANCE AND MINOR REPAIR

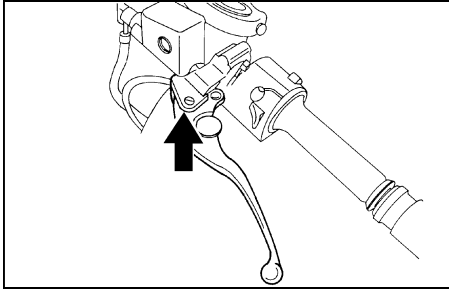

EAU02985

Brake and clutch lever lubrication

Lubricate the pivoting parts.

Recommended lubricant:
Engine oil

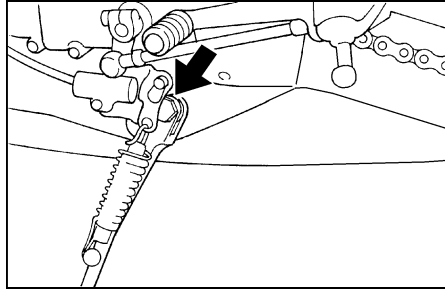

EAU00790

Rear suspension lubrication

Lubricate the pivoting parts.

Recommended lubricant:
Molybdenum disulfide grease

EAU02986

Sidestand lubrication

Lubricate the sidestand pivoting point and metal-to-metal contact surfaces. Check that the sidestand moves up and down smoothly.

Recommended lubricant:
Engine oil

EW000113

WARNING

If the sidestand does not move smoothly, consult a Yamaha dealer.

PERIODIC MAINTENANCE AND MINOR REPAIR

Front fork inspection

Visual check

EAU02939

EW000115

WARNING

Securely support the motorcycle so there is no danger of it falling over.

Check for scratches or damage on the inner tube and excessive oil leakage from the front fork.

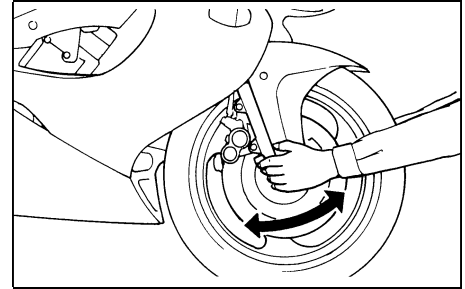
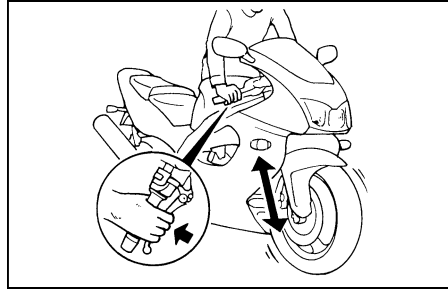

Operation check

1. Place the motorcycle on a level place.
2. Hold the motorcycle in an upright position and apply the front brake.
3. Push down hard on the handlebars several times and check if the fork rebounds smoothly.

EC000098

CAUTION:

If any damage or unsmooth movement is found with the front fork, consult a Yamaha dealer.

Steering inspection

EAU00794

Periodically inspect the condition of the steering. Worn out or loose steering bearings may be dangerous. Place a stand under the engine to raise the front wheel off the ground. Hold the lower end of the front forks and try to move them forward and backward. If any free play can be felt, ask a Yamaha dealer to inspect and adjust the steering. Inspection is easier if the front wheel is removed.

EW000115

WARNING

Securely support the motorcycle so there is no danger of it falling over.

PERIODIC MAINTENANCE AND MINOR REPAIR

Wheel bearings

EAU01144

If there is play in the front or rear wheel hub or if the wheel does not turn smoothly, have a Yamaha dealer inspect the wheel bearings.

Battery

EAU00800

This motorcycle is equipped with a sealed-type battery. Therefore it is not necessary to check the electrolyte or fill the battery with distilled water.

- If the battery seems to have discharged, consult a Yamaha dealer.
- If the motorcycle is equipped with optional electrical accessories, the battery tends to discharge more quickly, so be sure to recharge it periodically.

EC000101

CAUTION:

Never try to remove the sealing caps of the battery cells. The battery will be damaged.

WARNING

Battery electrolyte is poisonous and dangerous, causing severe burns, etc. It contains sulfuric acid. Avoid contact with skin, eyes or clothing.

ANTIDOTE:

- **EXTERNAL:** Flush with water.
- **INTERNAL:** Drink large quantities of water or milk. Follow with milk of magnesia, beaten egg, or vegetable oil. Call a physician immediately.
- **EYES:** Flush with water for 15 minutes and get prompt medical attention.

Batteries produce explosive gases. Keep sparks, flame, cigarettes etc., away. Ventilate when charging or using in an enclosed space. Always shield your eyes when working near batteries.

KEEP OUT OF REACH OF CHILDREN.

EW000116

PERIODIC MAINTENANCE AND MINOR REPAIR

Battery storage

When the motorcycle is not used for a month or longer, remove the battery, fully charge it and store it in a cool, dry place.

EC000102

CAUTION:

- Completely recharge the battery before storing. Storing a discharged battery can cause permanent battery damage.
- Use a battery charger designed for a sealed-type (MF) battery. Using a conventional battery charger will cause battery damage. If you do not have a sealed-type battery charger, contact your Yamaha dealer.
- Always make sure the connections are correct when reinstalling the battery.

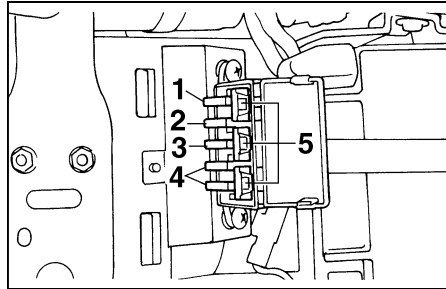

1. Headlight fuse
2. Ignition fuse
3. Signaling system fuse
4. Fan fuse (× 2)
5. Spare fuse (× 3)

EAU00820

Fuse replacement

One fuse box is located under the rider's seat and the other is located behind cowling B. (See page 6-5.) If any fuse is blown, turn off the main switch and the switch of the circuit in question. Install a new fuse of specified amperage. Turn on the switches and see if the electrical device operates. If the fuse immediately blows again, consult a Yamaha dealer.

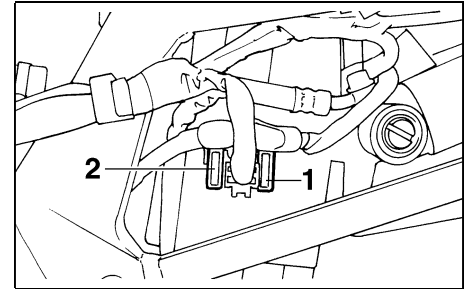

1. Main fuse
2. Spare fuse

EC000103

CAUTION:

Do not use fuses of higher amperage rating than those recommended. Substitution of a fuse of improper rating can cause extensive electrical system damage and possibly a fire.

PERIODIC MAINTENANCE AND MINOR REPAIR

Specified fuse:

Main fuse:	30 A
Headlight fuse:	20 A
Signaling system fuse:	15 A
Fan fuse:	7.5 A
Ignition fuse:	15 A

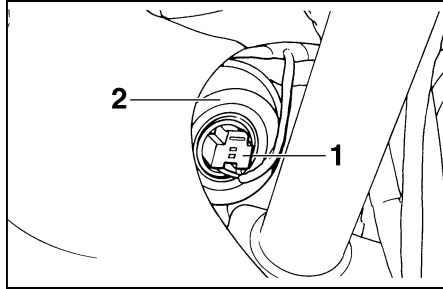

1. Connector
2. Bulb holder cover

EAU00827

Headlight bulb replacement

This motorcycle is equipped with a quartz bulb headlight. If the headlight bulb burns out, replace the bulb as follows:

1. Remove the connectors and the bulb holder cover.

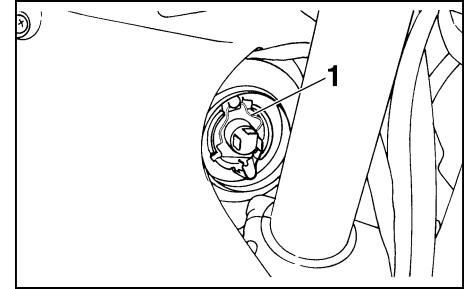

1. Bulb holder
2. Unhook the bulb holder and remove the defective bulb.

EW000119

WARNING

Keep flammable products and your hands away from a bulb while it is on, as it is hot. Do not touch a bulb until it cools down.

3. Put a new bulb into position and secure it in place with the bulb holder.

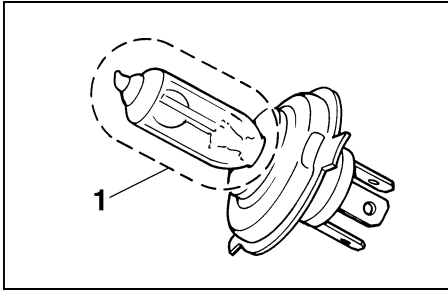

1. Don't touch

EC000105

CAUTION:

Avoid touching the glass part of a bulb. Keep it free from oil; otherwise, the transparency of the glass, life of the bulb, and luminous flux will be adversely affected. If oil gets on a bulb, thoroughly clean it with a cloth moistened with alcohol or lacquer thinner.

4. Install the bulb holder cover and reconnect the headlight connectors. If the headlight beam adjustment is necessary, ask a Yamaha dealer to make that adjustment.

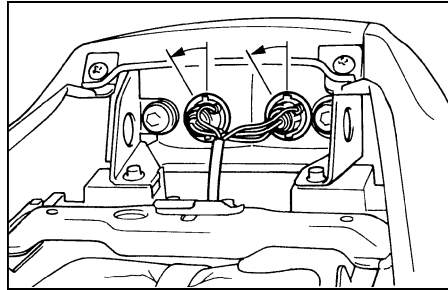

EAU01823*

Tail/brake light bulb replacement

1. Remove the passenger seat. (See page 3-14 for seat removal and installation procedures.)
2. To remove the socket, turn it counterclockwise.
3. To remove the defective bulb, turn it counterclockwise.
4. Push a new bulb into the socket and turn it clockwise.
5. Install the socket and turn it clockwise.
6. Install the passenger seat.

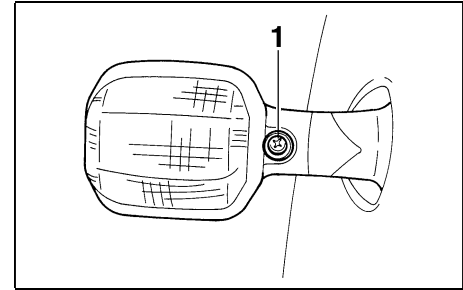

1. Screw

EAU01095

Turn signal light bulb replacement

1. Remove the screw and the lens.
2. Remove the defective bulb by pushing it inward and turning it counterclockwise.
3. Install a new bulb by pushing it inward and turning it clockwise.
4. Install the lens and tighten the screw.

PERIODIC MAINTENANCE AND MINOR REPAIR

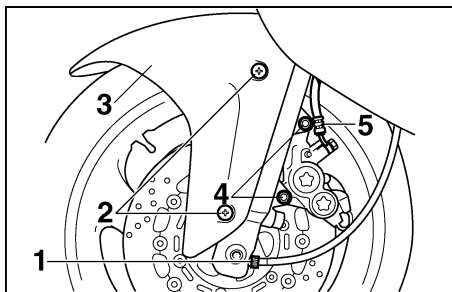

1. Speedometer cable
2. Front fender bolt (× 4)
3. Front fender
4. Caliper bolt (× 2)
5. Brake hose holder

EAU01252*

EW000122

6 Front wheel removal

WARNING

- It is advisable to have a Yamaha dealer service the wheel.
- Securely support the motorcycle so there is no danger of it falling over.

1. Remove the speedometer cable from the front wheel side.
2. Remove the front fender bolts and front fender.

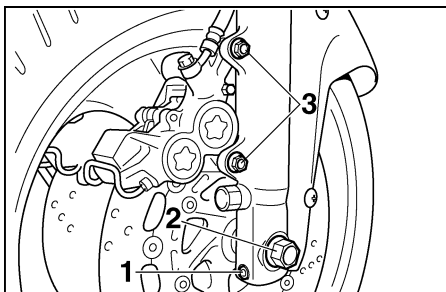

1. Pinch bolt
2. Wheel axle
3. Caliper bolt (× 2)

3. Loosen the pinch bolt, wheel axle and caliper bolts.
4. Elevate the wheel.
5. Remove the brake hose holders and calipers.

NOTE:

Do not depress the brake lever when the calipers are off the discs as the brake pads will be forced shut.

6. Remove the wheel axle and speedometer gear unit. Make sure the motorcycle is properly supported.

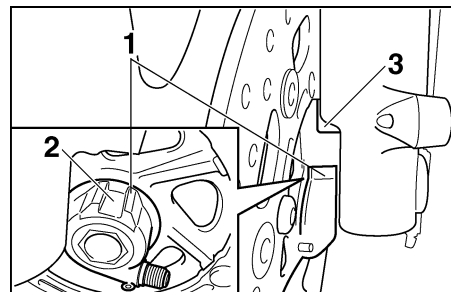

1. Speedometer gear unit
2. Slot
3. Stopper

EAU01469*

Front wheel installation

1. Install the speedometer gear unit into the wheel hub. Make sure the wheel hub and the speedometer gear unit are installed with the projections meshed into the slots.
2. Lift up the wheel between the front fork legs. Make sure the slot in the speedometer gear unit fits over the stopper on the front fork outer tube.
3. Install the wheel axle and let the motorcycle down.

PERIODIC MAINTENANCE AND MINOR REPAIR

4. Install the calipers, caliper bolts and brake hose holders. Make sure there is enough gap between the brake pads before installing the calipers onto the brake discs.
5. Tighten the wheel axle, pinch bolt and caliper bolts to the specified torques.

Tightening torque:

Wheel axle:

72 Nm (7.2 m·kg)

Pinch bolt:

23 Nm (2.3 m·kg)

Caliper bolt:

40 Nm (4.0 m·kg)

6. Push down hard on the handlebars several times to check for proper fork operation.
7. Install the speedometer cable.
8. Install the front fender and bolts.

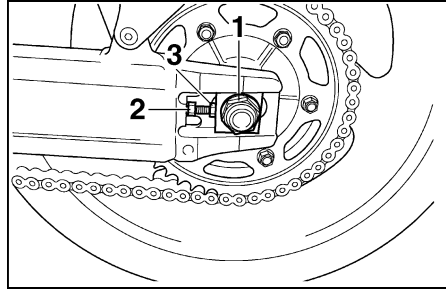

1. Axle nut
2. Adjusting bolt
3. Locknut

EAU01247*

Rear wheel removal

EW000122

⚠ WARNING

- It is advisable to have a Yamaha dealer service the wheel.
- Securely support the motorcycle so there is no danger of it falling over.

1. Loosen the axle nut and caliper bolts.
2. Elevate the rear wheel.

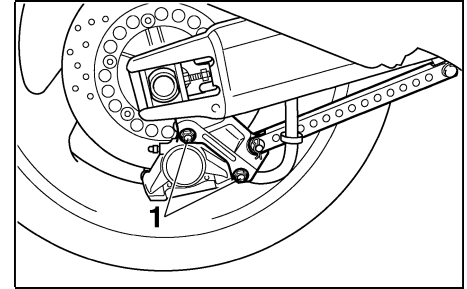

1. Caliper bolt (× 2)

3. Remove the axle nut, caliper bolts and caliper.
4. Loosen the locknuts on each side of the swingarm.
5. Turn the chain adjusting bolts fully outward.
6. Push the wheel forward and remove the drive chain.
7. Pull out the wheel axle and remove the wheel assembly by pulling backwards.

PERIODIC MAINTENANCE AND MINOR REPAIR

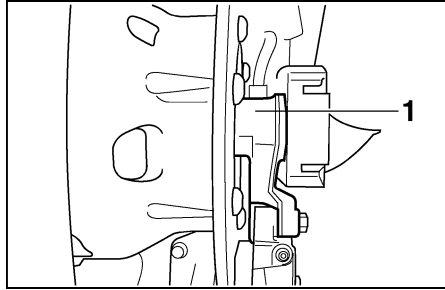
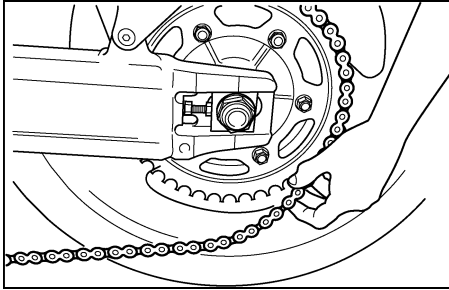

1. Caliper bracket

Tightening torque:

Axle nut:

150 Nm (15.0 m·kg)

Caliper bolt:

40 Nm (4.0 m·kg)

NOTE:

- Do not depress the brake pedal when the caliper is off the disc as the brake pads will be forced shut.
- You do not have to disassemble the chain in order to remove or install the rear wheel.

EAU01246*

Rear wheel installation

1. Install the wheel assembly, caliper bracket and insert the axle.
2. Install and adjust the drive chain. (See page 6-23 for details about adjusting the drive chain slack.)
3. Install the axle nut and let the motorcycle down.
4. Install the caliper and caliper bolts. Make sure there is enough gap between the brake pads before installing the caliper onto the brake disc.
5. Tighten the axle nut and caliper bolts to the specified torques.

EAU01008

Troubleshooting

Although Yamaha motorcycles receive a rigid inspection before shipment from the factory, trouble may occur during operation.

Any problem in the fuel, compression, or ignition systems can cause poor starting and loss of power. The troubleshooting chart describes a quick, easy procedure for making checks.

If your motorcycle requires any repair, bring it to a Yamaha dealer. The skilled technicians at a Yamaha dealership have the tools, experience, and know-how to properly service your motorcycle. Use only genuine Yamaha parts on your motorcycle. Imitation parts may look like Yamaha parts, but they are often inferior. Consequently, they have a shorter service life and can lead to expensive repair bills.

PERIODIC MAINTENANCE AND MINOR REPAIR

Troubleshooting chart

EAU02990*

EW000125



WARNING

Never check the fuel system while smoking or in the vicinity of an open flame.

1. Fuel

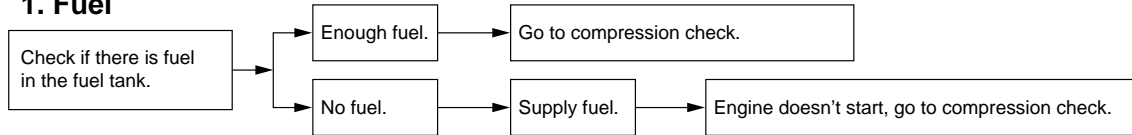

2. Compression

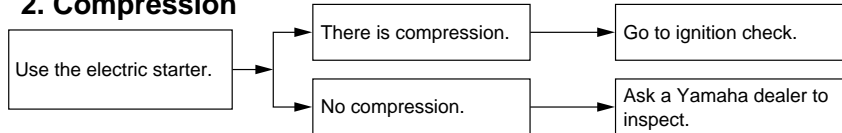

3. Ignition

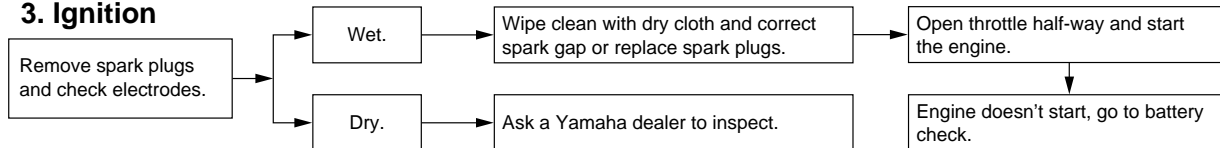

4. Battery

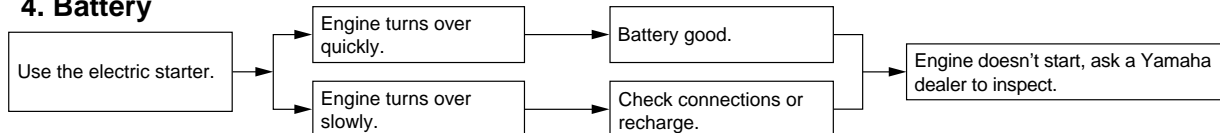

PERIODIC MAINTENANCE AND MINOR REPAIR

Engine overheating

EW000070

WARNING

Do not remove the radiator cap when the engine and radiator are hot. Scalding hot fluid and steam may be blown out under pressure, which could cause serious injury. Open the radiator cap as follows. Wait until the engine has cooled. Remove the radiator cap stopper by removing the screw. Place a thick rag like a towel over the radiator cap and slowly rotate the cap counterclockwise to the detent. This procedure allows any residual pressure to escape. When the hissing sound has stopped, press down on the cap while turning counterclockwise and remove it.

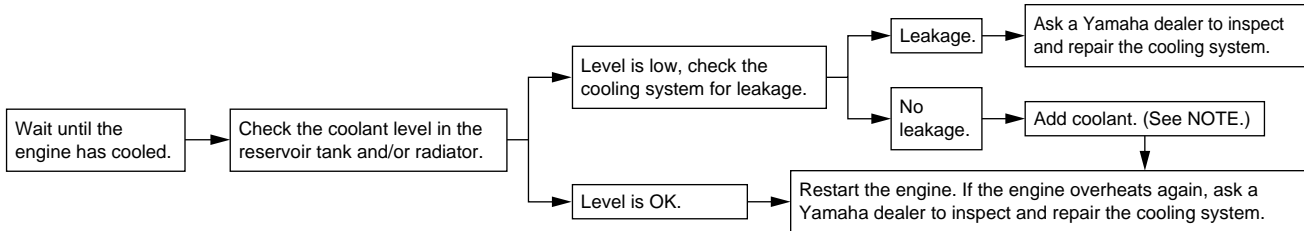

NOTE:

If it is difficult to get the recommended coolant, tap water can be temporarily used, provided that it is changed to the recommended coolant as soon as possible.

MOTORCYCLE CARE AND STORAGE

Care	7-1
Storage.....	7-4

Care

The exposure of its technology makes a motorcycle charming but also vulnerable. Although high-quality components are used, they are not all rust-resistant. While a rusty exhaust pipe may remain unnoticed on a car, it does look unattractive on a motorcycle. Frequent and proper care, however, will keep your motorcycle looking good, extend its life and maintain its performance. Moreover, the warranty states that the vehicle must be properly taken care of. For all these reasons, it is recommended that you observe the following cleaning and storing precautions.

Before cleaning

1. Cover up the muffler outlet with a plastic bag.
2. Make sure that all caps and covers as well as all electrical couplers and connectors, including the spark plug caps, are tightly installed.
3. Remove extremely stubborn dirt, like oil burnt onto the crankcase, with a degreasing agent and a brush, but never apply such products onto seals, gaskets, sprockets, the drive chain and wheel axles. Always rinse the dirt and degreaser off with water.

Cleaning

After normal use

Remove dirt with warm water, a neutral detergent and a soft clean sponge, then rinse with plenty of clean water. Use a tooth or bottle brush for hard-to-reach parts. Tougher dirt and insects will come off more easily if the area is covered with a wet cloth for a few minutes before cleaning.

MOTORCYCLE CARE AND STORAGE

ECA00010

CAUTION:

- Avoid using strong acidic wheel cleaners, especially on spoked wheels. If you do use such products for hard-to-remove dirt, do not leave it on any longer than instructed, then thoroughly rinse it off with water, immediately dry the area and apply a corrosion protection spray.
- Improper cleaning can damage windshields, cowlings, panels and other plastic parts. Use only a soft, clean cloth or sponge with mild detergent and water to clean plastic.
- Do not use any harsh chemical products on plastic parts. Be sure to avoid using cloths or sponges which have been in contact with strong or abrasive cleaning products, solvent or thinner, fuel (gasoline), rust removers or inhibitors, brake fluid, antifreeze or electrolyte.
- Do not use high-pressure washers or steam-jet cleaners since they cause water seepage and deterioration in the following areas: seals (of wheel bearings, swingarm bearings, forks and brakes), electric components (couplers, connectors, instruments, switches and lights), breather hoses and vents.
- For motorcycles equipped with a windshield: Do not use strong cleaners or hard sponges as they will cause dulling or scratching. Some cleaning compounds for plastic may leave scratches on the windshield. Test the product on a small hidden part of the windshield to make sure they do not leave any marks. If the windshield is scratched, use a quality plastic polishing compound after washing.

After riding in the rain, near the sea or on salt-sprayed roads

Since sea salt or salt sprayed on the roads in the winter are extremely corrosive in combination with water, carry out the following steps after each ride in the rain, near the sea or on salt-sprayed roads. (Salt sprayed in the winter may remain on the roads well into spring.)

MOTORCYCLE CARE AND STORAGE

1. Clean your motorcycle with cold water and soap after the engine has cooled down.

ECA00012

CAUTION:

Do not use warm water since it increases the corrosive action of the salt.

2. Be sure to apply a corrosion protection spray on all (even chrome- and nickel-plated) metal surfaces to prevent corrosion.

After cleaning

1. Dry the motorcycle with a chamois or an absorbing cloth.
2. Immediately dry the drive chain and lubricate it to prevent it from rusting.
3. Use a chrome polish to shine chrome, aluminum and stainless-steel parts, including the exhaust system. (Even the thermally induced discoloring of stainless-steel exhaust systems can be removed through polishing.)
4. To prevent corrosion, it is recommended to apply a corrosion protection spray on all (even chrome- and nickel-plated) metal surfaces.
5. Use spray oil as a universal cleaner to remove any remaining dirt.
6. Touch up minor paint damage caused by stones, etc.
7. Wax all painted surfaces.
8. Let the motorcycle dry completely before storing it or covering it.

EWA00001

! WARNING

Make sure that there is no oil or wax on the brakes and tires. If necessary, clean the brake discs and linings with a regular brake disc cleaner or acetone, and wash the tires with warm water and mild soap. Then, carefully test the motorcycle for its braking performance and cornering behavior.

MOTORCYCLE CARE AND STORAGE

ECA00013

CAUTION:

- Apply spray oil and wax sparingly and wipe off any excess.
- Never apply oil or wax on rubber and plastic parts, but treat them with a suitable care product.
- Avoid using abrasive polishing compounds as they wear away the paint.

NOTE:

Consult a Yamaha dealer for advice on what products to use.

Storage

Short-term

Always store your motorcycle in a cool, dry place and, if necessary, protect it against dust with a porous cover.

ECA00014

CAUTION:

- Storing the motorcycle in a poorly ventilated room or covering it with a tarp while it is still wet will allow water and humidity to seep in and cause rust.
- To prevent corrosion, avoid damp cellars, stables (because of the presence of ammonia) and areas where strong chemicals are stored.

Long-term

Before storing your motorcycle for several months:

1. Follow all the instructions in the “Care” section of this chapter.
2. Drain the carburetor float chambers by loosening the drain bolts; this will prevent fuel deposits from building up. Pour the drained fuel into the fuel tank.
3. Only for motorcycles equipped with a fuel cock which has an “OFF” position: Turn the fuel cock to “OFF”.
4. Fill up the fuel tank and add fuel stabilizer (if available) to prevent the fuel tank from rusting and the fuel from deteriorating.
5. Perform the following steps to protect the cylinders, piston rings, etc. from corrosion.

MOTORCYCLE CARE AND STORAGE

- a. Remove the spark plug caps and spark plugs.
- b. Pour a teaspoonful of engine oil into each spark plug bore.
- c. Install the spark plug caps onto the spark plugs and place the spark plugs on the cylinder head so that the electrodes are grounded. (This will limit sparking during the next step.)
- d. Turn the engine over several times with the starter. (This will coat the cylinder walls with oil.)
- e. Remove the spark plug caps from the spark plugs, install the spark plugs and then the spark plug caps.
6. Lubricate all control cables and the pivoting points of all levers and pedals as well as of the sidestand/centerstand.
7. Check and, if necessary, correct the tire air pressure, then raise the motorcycle so that both of its wheels are off the ground. Alternatively, turn the wheels a little every month in order to prevent the tires from becoming degraded in one spot.
8. Cover up the muffler outlet with a plastic bag to prevent moisture from entering.
9. Remove the battery and fully charge it. Store it in a cool, dry place and recharge it once a month. Do not store the battery in an excessively cold or warm place (less than 0 °C or more than 30 °C). For more information, see “Battery storage” in the chapter “PERIODIC MAINTENANCE AND MINOR REPAIRS”.

NOTE: _____
Make any necessary repairs before storing the motorcycle.

7

EWA00003

WARNING

When turning the engine over, be sure to ground the spark plug electrodes to prevent damage or injury from sparking.

Specifications 8-1
HOW TO USE THE CONVERSION TABLE 8-5

Specifications

Model	YZF1000R
Dimensions	
Overall length	2,085 mm (except for CH, D, DK, NL, S, SF) 2,170 mm (for CH, D, DK, NL, S, SF)
Overall width	740 mm
Overall height	1,175 mm
Seat height	815 mm
Wheelbase	1,430 mm
Ground clearance	140 mm
Minimum turning radius	3,100 mm
Basic weight (with oil and full fuel tank)	224 kg
Engine	
Engine type	Liquid-cooled 4-stroke, DOHC
Cylinder arrangement	Forward-inclined parallel 4-cylinder
Displacement	1,002 cm ³
Bore × Stroke	75.5 × 56.0 mm
Compression ratio	11.5:1
Starting system	Electric starter
Lubrication system	Wet sump

Engine oil

Type

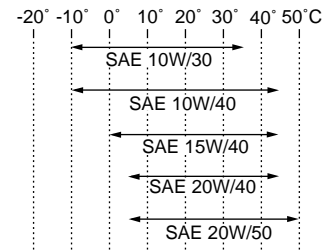

Recommended engine oil classification

API Service SE, SF, SG type or higher

CAUTION:

Be sure to use motor oils that do not contain anti-friction modifiers. Passenger car motor oils (often labeled “Energy Conserving”) contain anti-friction additives which will cause clutch and/or starter clutch slippage, resulting in reduced component life and poor engine performance.

Quantity

Periodic oil change	3.0 L
With oil filter replacement	3.2 L
Total amount	3.5 L

Air filter

Dry type element

SPECIFICATIONS

Fuel	
Type	Regular unleaded gasoline
Fuel tank capacity	20 L
Reserve amount	4.5 L
Carburetor	
Type × quantity	BDSR38 × 4
Manufacturer	MIKUNI
Spark plug	
Manufacturer/type	NGK / DR8EA or DENSO / X24ESR-U
Gap	0.6 ~ 0.7 mm
Clutch type	Wet, multiple-disc
Transmission	
Primary reduction system	Spur gear
Primary reduction ratio	1.659
Secondary reduction system	Chain drive
Secondary reduction ratio	2.706 (except for D, S, SF) 2.765 (for D, S, SF)
Transmission type	Constant mesh 5-speed
Operation	Left foot operation
Gear ratio	
	1st 2.571
	2nd 1.778
	3rd 1.381
	4th 1.174

	5th	1.037
Chassis		
Frame type		Diamond
Caster angle		24°
Trail		97 mm
Tire		
Front		
	Type	Tubeless
	Size	120/70 ZR17
	Manufacturer/ model	Bridgestone / BT50F Dunlop / D204FN Michelin / MACADAM 90XM Metzeler / MEZ1 Metzeler / MEZ2
Rear		
	Type	Tubeless
	Size	180/55 ZR17
	Manufacturer/ model	Bridgestone / BT50R Dunlop / D204M Michelin / MACADAM 90XM Metzeler / MEZ1 Metzeler / MEZ2

SPECIFICATIONS

Maximum load*	196 kg
Air pressure (cold tire)	
up to 90 kg load*	
Front	250 kPa (2.50 kg/cm ² , 2.50 bar)
Rear	250 kPa (2.50 kg/cm ² , 2.50 bar)
90 kg load ~ maximum load*	
Front	290 kPa (2.90 kg/cm ² , 2.90 bar)
Rear	290 kPa (2.90 kg/cm ² , 2.90 bar)
High speed riding	
Front	290 kPa (2.90 kg/cm ² , 2.90 bar)
Rear	290 kPa (2.90 kg/cm ² , 2.90 bar)

* Load is total weight of cargo, rider, passenger and accessories.

Wheels

Front	
Type	Cast
Size	17 × MT 3.50
Rear	
Type	Cast
Size	17 × MT 5.50

Brakes

Front	
Type	Dual disc brake
Operation	Right hand operation
Fluid	DOT 4

Rear	
Type	Single disc brake
Operation	Right foot operation
Fluid	DOT 4

Suspension

Front	
Type	Telescopic fork
Inner tube outer diameter	48 mm
Rear	
Type	Swingarm (link suspension)

Shock absorbers

Front	Coil spring/oil damper
Rear	Coil spring/gas-oil damper

Wheel travel

Front	120 mm
Rear	120 mm

Electrical systems

Ignition system	T.C.I. (digital)
Charging system	
Type	A.C. generator
Standard output	12 V, 28 A @ 5,000 r/min
Battery	
Type	YTX14-BS
Voltage, capacity	12 V, 12 AH

Headlight type	Quartz bulb (halogen)
Bulb voltage, wattage × quantity	
Headlight	12 V, 60/55 W (except for GB) 12 V, 35/35 W × 2 (for GB)
Auxiliary light	12 V, 5 W × 1
Tail/brake light	12 V, 5/21 W × 2
Turn signal lights	12 V, 21 W × 4
Meter light	12 V, 1.7 W × 4
Neutral indicator light	12 V, 3.4 W × 1
High beam indicator light	12 V, 3.4 W × 1
Oil level indicator light	12 V, 3.4 W × 1
Turn indicator light	12 V, 3.4 W × 1
Fuel indicator light	12 V, 3.4 W × 1
Fuses	
Main fuse	30 A
Ignition fuse	15 A
Signaling system fuse	15 A
Headlight fuse	20 A
Fan fuse	7.5 A

SPECIFICATIONS

EAU01064

HOW TO USE THE CONVERSION TABLE

All specification data in this manual are listed in SI and METRIC UNITS.

Use this table to convert METRIC unit data to IMPERIAL unit data.

Ex.

METRIC		MULTIPLIER	=	IMPERIAL
**mm	×	0.03937	=	**in
2 mm	×	0.03937	=	0.08 in

CONVERSION TABLE

METRIC TO IMPERIAL			
	Metric unit	Multiplier	Imperial unit
Torque	m-kg	7.233	ft-lb
	m-kg	86.794	in-lb
	cm-kg	0.0723	ft-lb
	cm-kg	0.8679	in-lb
Weight	kg	2.205	lb
	g	0.03527	oz
Speed	km/hr	0.6214	mph
Distance	km	0.6214	mi
	m	3.281	ft
	m	1.094	yd
	cm	0.3937	in
	mm	0.03937	in
Volume / Capacity	cc (cm ³)	0.03527	oz (IMP liq.)
	cc (cm ³)	0.06102	cu-in
	lt (liter)	0.8799	qt (IMP liq.)
	lt (liter)	0.2199	gal (IMP liq.)
Misc.	kg/mm	55.997	lb/in
	kg/cm ²	14.2234	psi (lb/in ²)
	Centigrade (°C)	9/5 + 32	Fahrenheit (°F)

Identification number records	9-1
Key identification number	9-1
Vehicle identification number.....	9-1
Model label.....	9-2

Identification number records

EAU02944

Record the key identification number, vehicle identification number and model label information in the spaces provided for assistance when ordering spare parts from a Yamaha dealer or for reference in case the vehicle is stolen.

1. KEY IDENTIFICATION NUMBER:

2. VEHICLE IDENTIFICATION NUMBER:

3. MODEL LABEL INFORMATION:

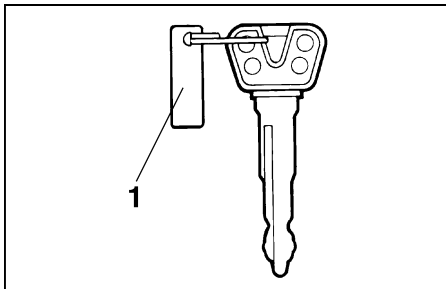

1. Key identification number

EAU01041

Key identification number

The key identification number is stamped on the key tag. Record this number in the space provided and use it for reference when obtaining a new key.

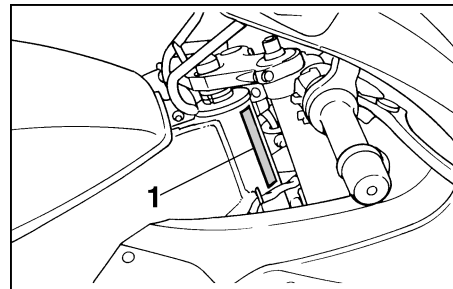

1. Vehicle identification number

EAU01043

Vehicle identification number

The vehicle identification number is stamped into the steering head pipe. Record this number in the space provided.

NOTE:

The vehicle identification number is used to identify your motorcycle and may be used to register your motorcycle with the licensing authority in your state.

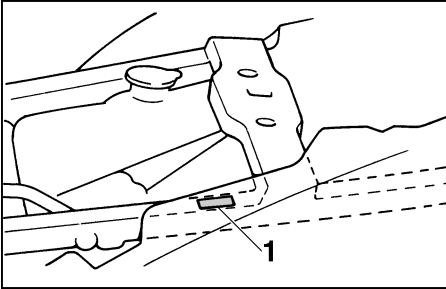

1. Model label

EAU01050

Model label

The model label is affixed to the frame under the seat. (See page 3-13 for seat removal procedures.) Record the information on this label in the space provided. This information will be needed to order spare parts from your Yamaha dealer.

INDEX

A

Air filter 6-12

B

Battery 6-27

Brake and clutch lever lubrication 6-25

Brake and shift pedal lubrication 6-24

Brake fluid replacement 6-22

Brake light switch adjustment 6-19

C

Cable inspection and lubrication 6-24

Carburetor adjustment 6-14

Care 7-1

Checking the front and rear brake

 pads 6-20

Clutch lever 3-9

Controls/Instruments 2-3

Coolant 6-11

Coolant temperature gauge 3-7

Cowling A 6-5

Cowling B 6-5

Cowling C 6-6

Cowling removal and installation 6-5

D

Diagnosis device 3-7

Dimmer switch 3-8

Drive chain lubrication 6-24

Drive chain slack adjustment 6-23

Drive chain slack check 6-23

E

Engine break-in 5-5

Engine oil 6-9

Engine stop switch 3-9

EXUP (EXhaust Ultimate Powervalve) ... 3-19

F

Front brake lever 3-10

Front fork adjustment 3-15

Front fork inspection 6-26

Front wheel installation 6-31

Front wheel removal 6-31

Fuel 3-12

Fuel indicator circuit check 3-5

Fuel indicator light 3-4

Fuel tank breather hose
(for Germany only) 3-13

Fuel tank cap 3-11

Fuse replacement 6-28

G

Give safety the right of way 1-1

H

Handlebar switches 3-8

 Dimmer switch 3-8

 Engine stop switch 3-9

 Horn switch 3-8

 Lights switch 3-9

 Pass switch 3-8

 Start switch 3-9

 Turn signal switch 3-8

Headlight bulb replacement 6-29

Helmet holder 3-14

High beam indicator light 3-2

Horn switch 3-8

I

Identification number records 9-1

Idle speed adjustment 6-15

Indicator lights 3-2

 Fuel indicator light 3-4

 High beam indicator light 3-2

 Neutral indicator light 3-2

 Oil level indicator light 3-2

 Turn indicator light 3-2

Inspecting the brake fluid level 6-21

K

Key identification number 9-1

L

Left view 2-1

Lights switch 3-9

Luggage strap holders 3-19

M

Main switch/steering lock 3-1

Model label 9-2

N

Neutral indicator light 3-2

O

Oil level indicator circuit check 3-3

Oil level indicator light 3-2

P

Parking 5-6

Pass switch 3-8

Periodic maintenance and lubrication 6-2

Pre-operation check list 4-1

R

Rear brake pedal	3-11
Rear shock absorber adjustment	3-17
Rear suspension lubrication.....	6-25
Rear wheel installation.....	6-33
Rear wheel removal.....	6-32
Recommended shift points (for Switzerland only).....	5-5
Right view.....	2-2

S

Seats	3-13
Shifting	5-4
Shift pedal	3-10
Sidestand	3-19
Sidestand/clutch switch operation check	3-20
Sidestand lubrication	6-25
Spark plugs	6-7
Specifications	8-1
Speedometer.....	3-6
Starter (choke) " \ ".....	3-13
Starting a warm engine.....	5-4
Starting the engine	5-1
Start switch.....	3-9
Steering inspection	6-26
Storage.....	7-4
Storage compartment	3-15

T

Tachometer	3-6
Tail/brake light bulb replacement	6-30
Throttle cable free play inspection	6-15
Tips for reducing fuel consumption	5-5

Tires.....	6-16
Tool kit	6-1
Troubleshooting	6-34
Troubleshooting chart	6-35
Turn indicator light.....	3-2
Turn signal light bulb replacement.....	6-30
Turn signal switch	3-8

V

Valve clearance adjustment	6-16
Vehicle identification number.....	9-1

W

Wheel bearings	6-27
Wheels.....	6-19



PRINTED ON RECYCLED PAPER

PRINTED IN JAPAN
99 · 8 - 0.6 × 1 CR
(E)